

The **WeatherPiArduino Weather Board** is an interface board for connecting a full featured, customizable board for Raspberry Pi and Arduino projects. It contains a built in I2C BMP180 Barometer/Temperature sensor includes a DS3231 RTC/EEPROM and contains interfaces for the following:

- SwitchDoc Labs WeatherRack Anemometer/Wind Vane/Rain Bucket (also supports SparkFun and ArgentData weather sensors)
- Embedded Adventures I2C Lightning Detector MOD-1016 board
- Adafruit HTU210-F Temperature/Humidity breakout board
- Adafruit 32KB FRAM I2C breakout board
- Adafruit ADS1015 4 Channel A/D I2C board

#### Features and Benefits:

- Provides an excellent interface for a Weather Station hookup to Raspberry Pi or Arduino
- Includes Arduino and Raspberry Pi Software
- Supports SwitchDoc Labs WeatherRack Wind Vane / Anemometer / Rain Bucket
- Control Panel available on RasPiConnect
- Contains I2C BMP180 Barometer/Temperature
- Includes DS3231 RTC/EEPROM
- Directly powers Raspberry Pi / Arduino
- Works with Raspberry Pi (3.3V) GPIO and Arduino (5.0V) GPIO
- Works with 3.3V and 5.0V I2C bus
- All onboard devices are 3.3V
- Supports I2C Lightning Detector MOD-1016
- Supports I2C HTU210-F Humidity Sensor
- Supports I2C 32KB FRAM
- Supports I2C ADS1015 4 Channel A/D
- Low Cost
- Full Test Code Supplied
- Quantity Discounts Available
- Immediate Availability

## Introduction

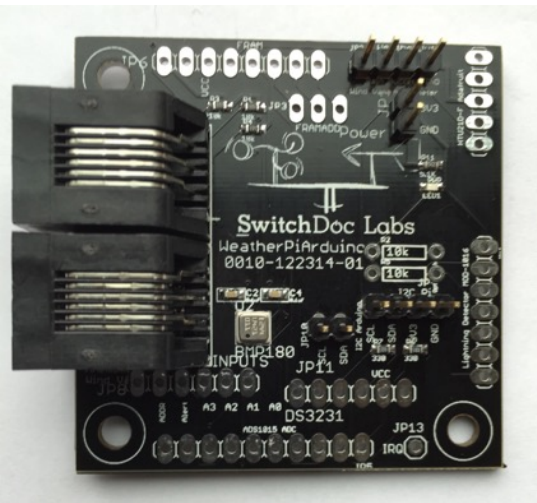

**WeatherPiArduino** is a weather station controller board designed to interface to Arduino and Raspberry Pi computers. It is an interface board developed by SwitchDoc Labs to allow the user to easily build a fully functioned Weather Station while allowing customization of functions.

WeatherPiArduino is derived from Project Curacao. Generation 1 of this board was deployed and tested on the island nation of Curacao before Generation 2 was released to production.

Combine the WeatherPiArduino with a SunAir or SunAirPlus board to create a solar powered weather station.

Additional code and examples on [www.switchdoc.com](http://www.switchdoc.com) on the

WeatherPiArduino Product Page

## Block Diagram

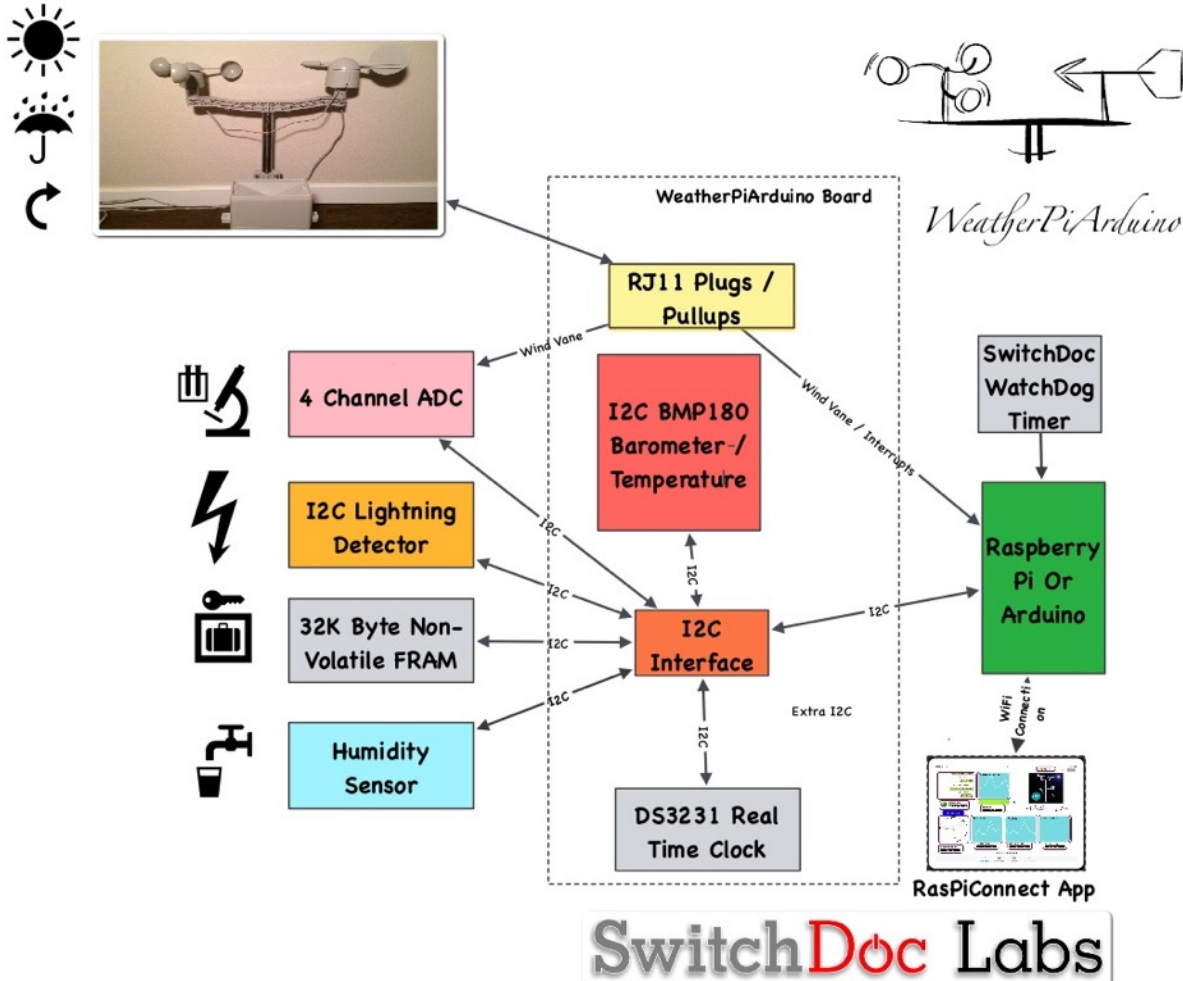

# SwitchDoc Labs

## Theory of Operation

---

### Software

Software and drivers for the WeatherPiArduino boards (including optional boards) for the Raspberry Pi and the Arduino can be located on the SwitchDoc Labs WeatherPiArduino product page ([www.switchdoc.com](http://www.switchdoc.com)).

---

### RJ11 Plugs / Pullups

The RJ11 Plugs on the WeatherPiArduino are designed to hook into inexpensive Anemometers, Wind Vanes and Rain Buckets. These plugs are wired to directly support the plugs coming from:

- SwitchDoc Labs WeatherRack (<http://www.switchdoc.com/weatherrack-weather-sensors/>). Available on the SwitchDoc Store and on Amazon.
  - ArgentData (<http://www.argentdata.com>)
  - SparkFun (<http://www.sparkfun.com>)
- 

### I2C Interface

The I2C interface has two parts. The 3.3V I2C interface (for Raspberry Pi) is on JP4. JP10 contains the interface for the Arduino. It provides voltage protection for the WeatherPiArduino devices from the 5V signals from the Arduino. Note that if you are using an Arduino, you **do not connect** the power pin on JP4 to 5V. Either connect it to 3.3V or leave it open. The pins are connected in series to a 330 Ohm resistor to drop the voltage.

---

### BMP180 Barometer / Temperature

The WeatherPiArduino board has an on board BMP180 Barometer / Temperature sensor connected to the I2C bus from the computer. The BMP180 is the function compatible successor of the BMP085.

With a low altitude noise of merely 0.25m at fast conversion time, the BMP180 offers superior performance. The BMP180 is based on piezo-resistive technology for EMC robustness, high accuracy and linearity as well as long term stability. The BMP180 consists of a piezo-resistive sensor, an analog to digital converter and a control unit with EEPROM and a serial I2C interface. The BMP180 delivers the uncompensated value of pressure and Temperature. Pressure data is 16 to 19 bits and temperature data is 16 bits.

The specifications for this device is on the SwitchDoc Labs WeatherPiArduino product page.

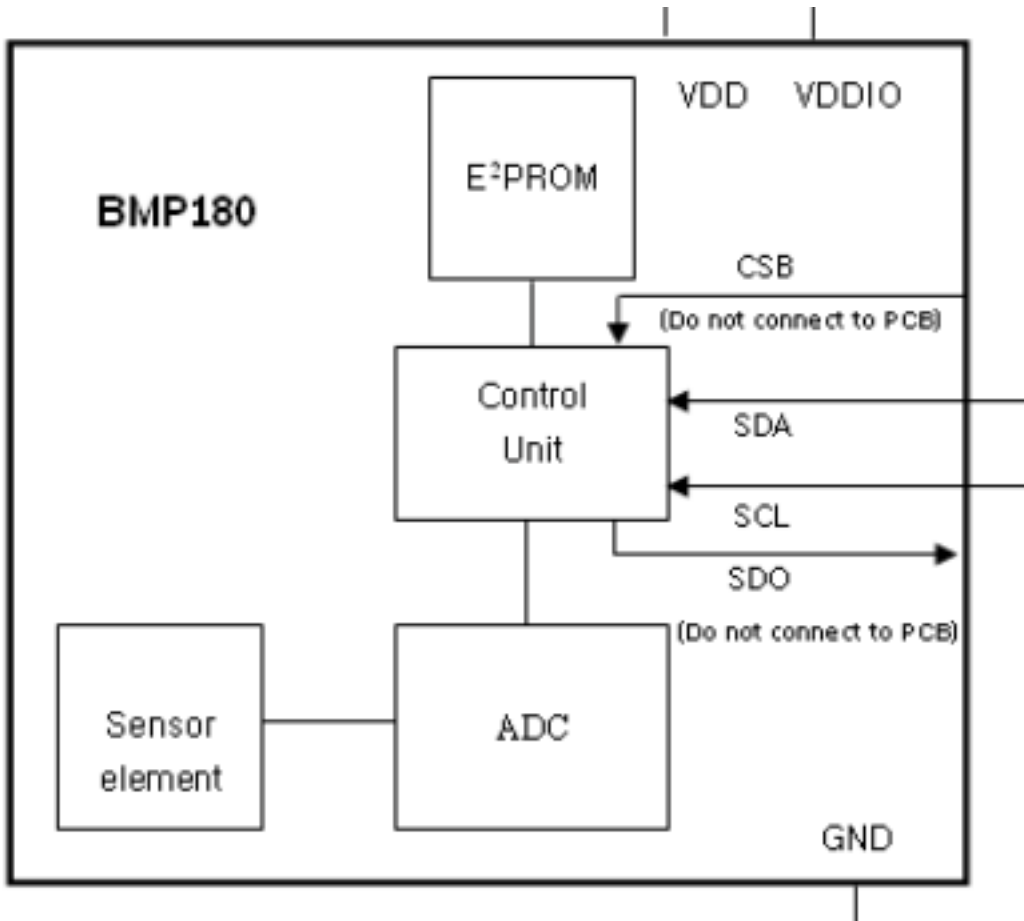

---

## DS3231/EEPROM Real Time Clock

The SwitchDoc Labs DS3231/EEPROM combination is included with the WeatherPiArduino board. It is plugged in by the user into JP11, taking care to having the battery facing the top of the board. **Note: when installing the DS3231 board bend the pins of J10 to a 45 degree angle away from the DS3231 board to allow those pins to be used and minimize the problem of shorting.**

The DS3231 is a low-cost, extremely accurate I<sup>2</sup>C real-time clock (RTC) with an integrated temperature-compensated crystal oscillator (TCXO) and crystal. The device incorporates a battery input, and maintains

accurate timekeeping when main power to the device is interrupted. The integration of the crystal resonator enhances the long-term accuracy of the device.

The RTC maintains seconds, minutes, hours, day, date, month, and year information. The date at the end of

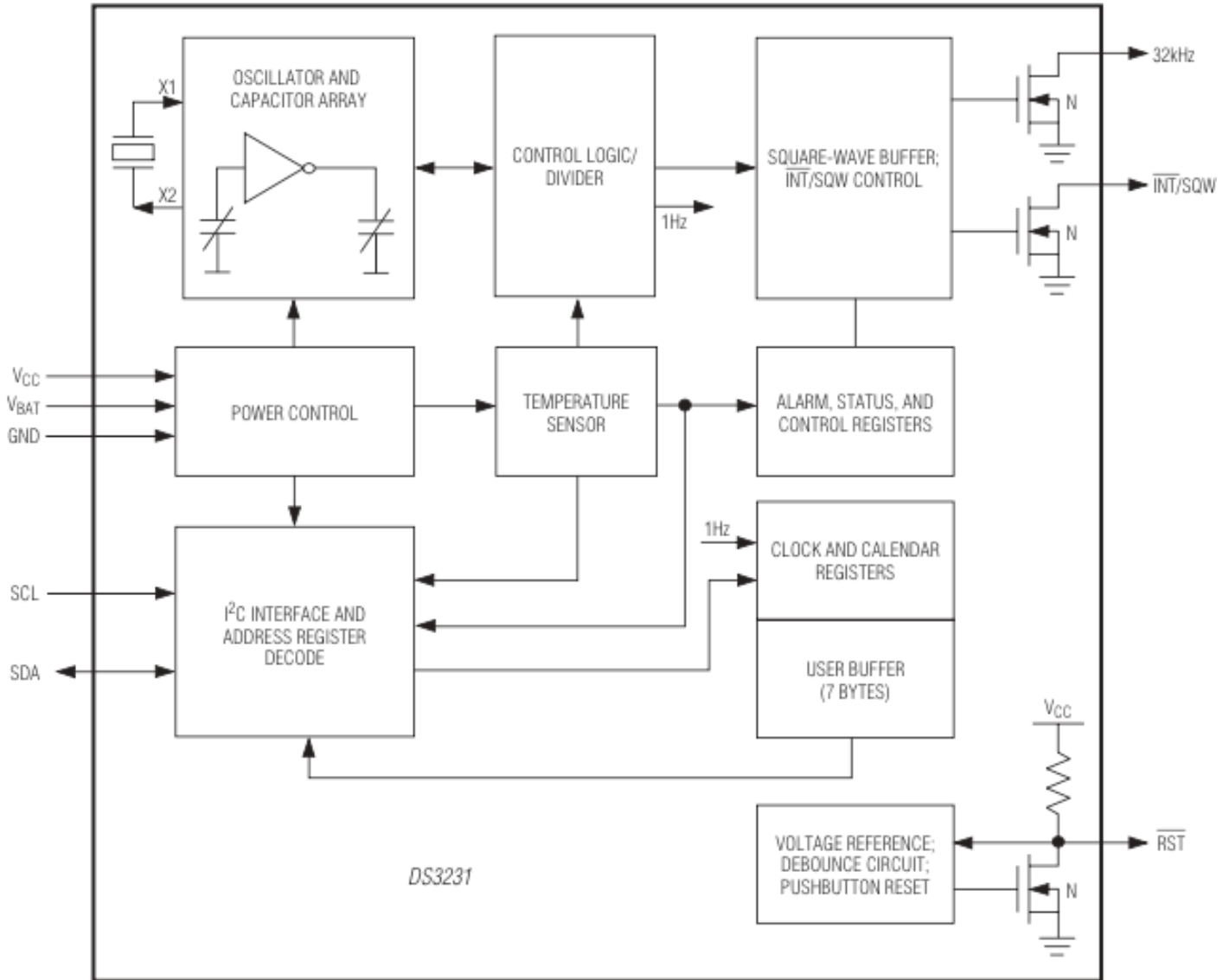

the month is automatically adjusted for months with fewer than 31 days, including corrections for leap year.

The clock operates in either the 24-hour or 12-hour format with an AM/PM indicator. Two programmable time-of-day alarms and a programmable square-wave output are provided. Address and data are transferred serially through the I2C bidirectional bus.

A precision temperature-compensated voltage reference and comparator circuit monitors the status of 3V3 to detect power failures, to provide a reset output, and to automatically switch to the backup supply (battery included) when necessary. Additionally, the RST pin is monitored as a pushbutton input for generating a  $\mu\text{P}$  reset.

The specifications for this device is on the SwitchDoc Labs WeatherPiArduino product page.

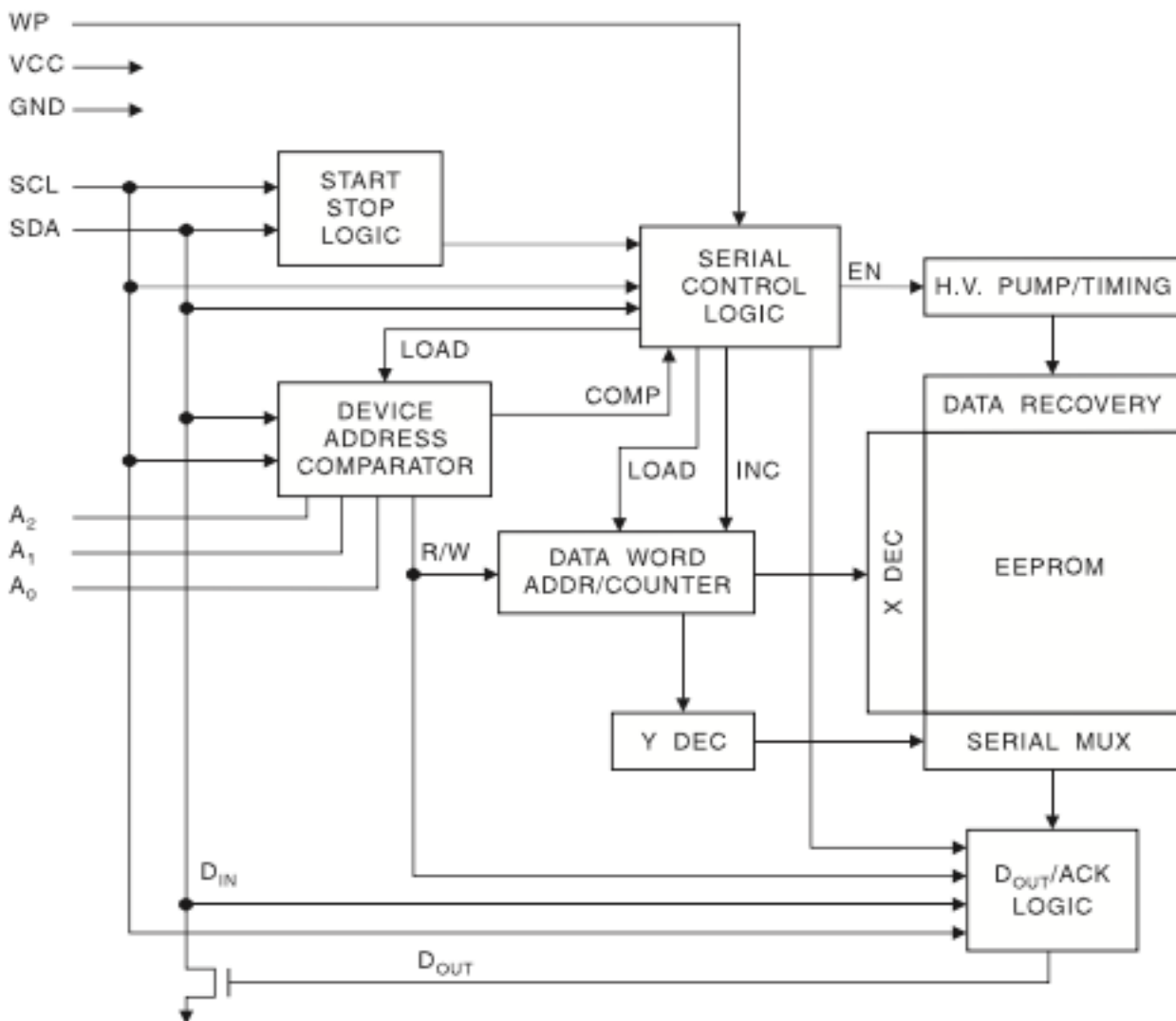

## AT24C32 32KB EEPROM

The AT24C32 provides 32,768 bits of serial electrically erasable and programmable read only memory (EEPROM) organized as 4096 words of 8 bits each. The EEPROM drivers are included in the SwitchDoc driver software.

---

## WeatherPiArduino Sensor Compatibility

The anemometer and rain bucket pins are pulled to 3.3V via a 10K Ohm pullup resistor. These are intended to connect to interrupt inputs on the host computer.

The standard Anemometer in these devices measures wind speed by closing a contact as a magnet moves past a switch. One contact closure a second indicates 1.492 MPH (2.4 km/h). If you use a different anemometer, this constant can be changed in software.

The tipping bucket Rain Gauge used in the SwitchDoc Labs WeatherRack, the SparkFun Weather Sensor and the ArgentData Sensors. The standard rain gauge used in these devices makes one momentary contact closure that can be recorded with a micro controller interrupt input. Each contact closure of the standard unit indicates 0.011 inch (0.2794 mm). If you use a different tipping rain gauge you can adjust these values in software.

The Wind vane has 8 switches, each connected to a different resistor. The WeatherPiArduino measures the resistance value of the resistor by measuring the voltage on a resistor divider (with 10K Ohm onboard resistor). With an Arduino, it is measured either with the optional ADS1015 or the internal A/D converters. In the case of a Raspberry Pi measuring this voltage requires an external A/D converter such as the optional ADS1015. See the SwitchDoc Labs WeatherRack Product Specification for more information on the Wind Vane.

See the SwitchDoc Labs drivers provided on [www.switchdoc.com](http://www.switchdoc.com).

Note that most RJ11 cables only have 4 wires instead of the six allowed by the plug.

The specifications for this device is on the SwitchDoc Labs WeatherPiArduino product page.

## Default I2C Addresses

The default I2C addresses for the on board devices and the optional devices are shown below.

DEVICE	DESCRIPTION	HEX ADDRESS	COMMENTS
BMP180	Barometer / Temperature	0x77	Included
DS3231	Real Time Clock	0x68	Included
AT24C32	EEPROM	0x56	Included
ADS1015	ADC	0x48	Optional Board. Can change I2C Addresses.
MOD-1016	Lightning Detector	0x03	Optional Board.
HTU210-F	Humidity Detector	0x40	Optional Board.
FRAM	32KB FRAM	0x50	Optional Board. Can change I2C Addresses.

## External Modules

There are a number of sources of each one of these external modules. If you do choose to use an alternative source of boards, make sure that you are connecting to the correct pins. The pinouts on WeatherPiArduino are set up for the following modules.

- Adafruit ADS1015 ADC - 12 bit 4 channel Analog to Digital Converter
- Embedded Adventures MOD-1016 Lightning Detector - detect nearby and far away lightning storms
- Adafruit Humidity Detector HTU210-F - humidity and temperature sensors
- Adafruit 32KB FRAM - very fast non-volatile RAM

The specifications for all of these devices are on the SwitchDoc Labs WeatherPiArduino product page.



## Operating Values

	Min	Normal	Max	Unit
3V3	3.313V	3.3V	3.465	V
I3v3*		5		mA

\*WeatherPiArduino Power Consumption depends on what other devices you have added to the board.

### WeatherPiArduino Board Jumper Pin and Plug Locations

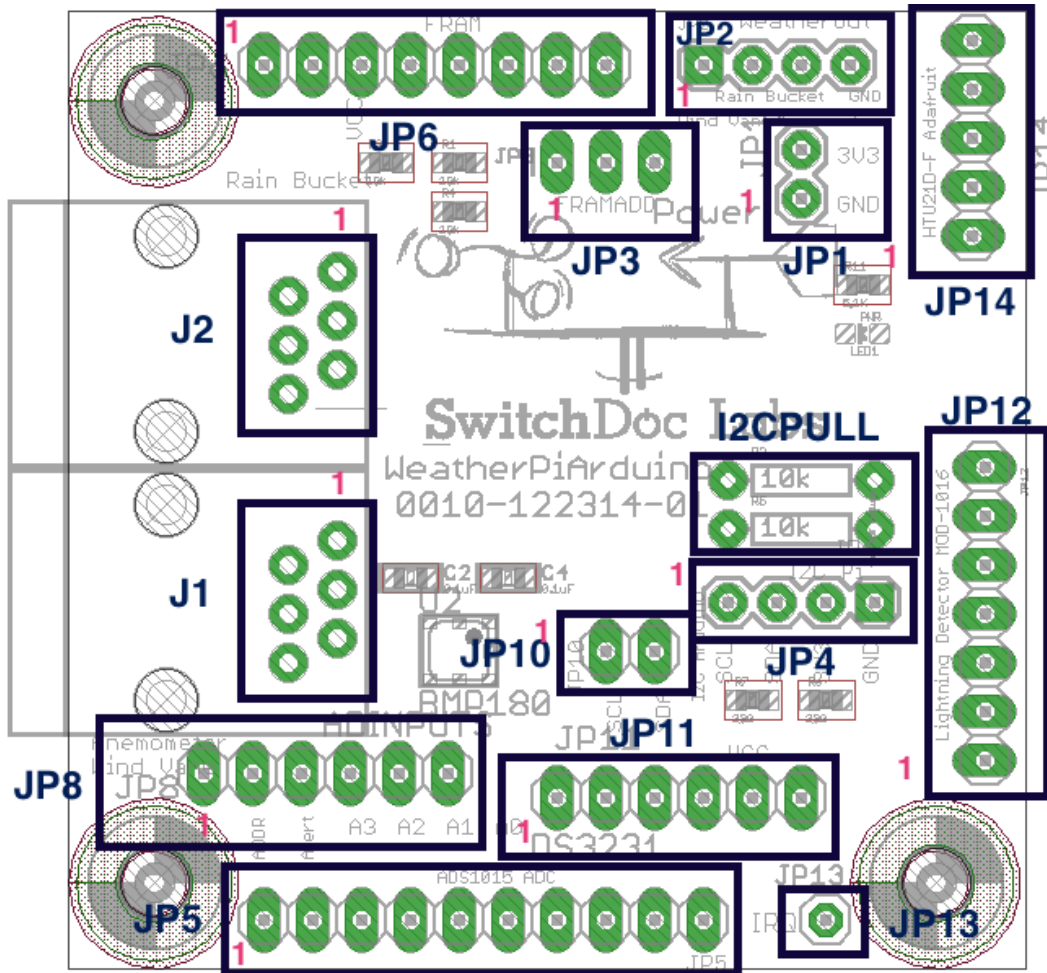

Physical dimensions of board: 50mm x 500mm x 14.5mm(max). Mounting holes inset 3.8mm x 3.8mm from each corner to center of hole. Diameter of hole 2mm.

**I/O Key:**

- I - Digital Input**
- O - Digital Output**
- A - Analog**

## Plug Functions

### J1 - Rain Bucket RJ11 Plug

Used to connect the WeatherPiArduino to a tipping bucket Rain Gauge used in the SwitchDoc Labs WeatherRack, the SparkFun Weather Sensor and the ArgentData Sensors. The standard rain gauge used in these devices makes one momentary contact closure that can be recorded with a micro controller interrupt input. Each contact closure of the standard unit indicates 0.011 inch (0.2794 mm). If you use a different tipping rain gauge you can adjust these values in software.

Note that most RJ11 cables only have 4 wires instead of the six allowed by the plug.

NAME	PIN	I/O	DESCRIPTION
N/C	J1 / 1		No Connection
N/C	J1 / 2		No Connection
GND	J1 / 3	A	Connected to GND
RainBucket Contact	J1 / 4	A	Connected to Rain Gauge ping on JP2 and 10K Ohm Pullup to 3V3
N/C	J1 / 5		No Connection
N/C	J1 / 6		No Connection

## J2 - Anemometer / Wind Vane RJ11 Plug

Used to connect the WeatherPiArduino board to a wind vane and anemometer such as used in the SwitchDoc Labs WeatherRack, the SparkFun Weather Sensor and the ArgentData Sensors. The standard Anemometer in these devices measures wind speed by closing a contact as a magnet moves past a switch. One contact closure a second indicates 1.492 MPH (2.4 km/h). If you use a different anemometer, this constant can be changed in software. The Wind vane has 8 switches, each connected to a different resistor. The WeatherPiArduino measures the resistance value of the resistor by measuring the voltage on a resistor divider (with 10 K Ohm resistor). With an Arduino, it is measured either with the optional ADS1015 or the internal A/D converters. In the case of a Raspberry Pi measuring this voltage requires an external A/D converter such as the optional ADS1015. See the SwitchDoc Labs WeatherRack Product Specification for more information on the Wind Vane.

NAME	PIN	I/O	DESCRIPTION
N/C	J2 / 1		No Connection
GND	J3 / 2	A	Connected to GND
GND	J3 / 3	A	Connected to GND
Anemometer	J4 / 4	A	Connected to Anemometer pin on JP2 and 10K Ohm Pullup to 3V3
Wind Vane	J5 / 5	A	Connected to Wind Vane Pin on JP2 and also to ADC-A1 on JP5 and JP8 for use by the optional ADS1015 ADC and 10K Ohm Pullup to 3V3
N/C	J6 / 6		No Connection

## Jumper Pin Functions

### JP1 - Power

Used to supply power to the WeatherPiArduino board.

NAME	PIN	I/O	DESCRIPTION
GND	JP1 / 1	A	Connected to GND
3V3	JP1 / 2	A	Connect to 3.3V ONLY

## JP2 - WeatherOut

This is the WeatherPiArduino output jumper to be used by the host computer.

NAME	PIN	I/O	DESCRIPTION
WindVane	JP2 / 1	O	Connect to A/D Input on Arduino. N/C for Raspberry Pi. Use an external ADC for Raspberry Pi (such as the Optional ADS1015 on the WeatherArduinoBoard)
RainBucket	JP2 / 2	O	Active Low Interrupt on each click of the Rain Bucket - Not Debounced.
Anemometer	JP2 / 3	I	Active Low Interrupt on each click of the Anemometer - Not Debounced.
GND	JP2 / 4	A	Connected to GND

## JP3 - Optional FRAM Address

Used to set other I2C addresses for the Optional I2C FRAM Module. The optional FRAM module is much faster to read and write to than the included EEPROM device. These are the I2C address selection pins. By default the I2C address is 0x50. Connecting these pins to 3V3 and power cycling the chip will adjust the lower three bits of the address. For example, if A0 is high, the address is 0x51. If A1 and A2 are high, the address is 0x56

NAME	PIN	I/O	DESCRIPTION
A2	JP3 / 1	I	High selection bit (use A2,A1,A0 as three bits and add to 0x50)
A1	JP3 / 2	I	Middle selection bit (use A2,A1,A0 as three bits and add to 0x50)
A0	JP3 / 3	I	Low selection bit (use A2,A1,A0 as three bits and add to 0x50)

## JP4 - I2C for Raspberry Pi

This is a 3.3V I2C bus for use by the Raspberry Pi. **Not a 5V I2C bus.** Use JP10 to connect 5V SCL and SDA from the Arduino.

NAME	PIN	I/O	DESCRIPTION
SCL	JP4 / 1	I	Serial bus clock line; open-drain input. No Pullup on board
SDA	JP4 / 2	I/O	Serial bus data line; open-drain input/output. No Pullup on board
3V3	JP4 / 3	A	Connected to 3V3 (3.3V I2C Bus)
GND	JP4 / 4	A	GND

## JP10 - I2C for Arduino

This is a 5V I2C bus for use by the Arduino. **Not a 3.3V I2C bus.** Use JP4 to connect 3.3V SCL and SDA from the Raspberry Pi. Note that if you are using an Arduino, you **do not connect** the power pin on JP4 to 5V. Either connect the pin to 3.3V or leave it open.

NAME	PIN	I/O	DESCRIPTION
SCL	JP10 / 1	I	5V Tolerant Serial bus clock line; open-drain input. No Pullup on board
SDA	JP10 / 2	I/O	5V Tolerant Serial bus data line; open-drain input/output. No Pullup on board

## JP5 - Optional ADS1015 ADC

The ADS1015 is a precision analog-to-digital converter (ADC) with 12 bits of resolution. The ADS1015 is designed with precision, power, and ease of implementation in mind. Data are transferred via an I2C-compatible serial interface; four I2C slave addresses can be selected.

The ADS1015 chips have a base 7-bit I2C address of 0x48 and an addressing scheme that allows four different addresses using just one address pin. To program the address, connect the address pin as follows:

- 0x48 (1001000) ADDR -> GND
- 0x49 (1001001) ADDR -> VDD
- 0x4A (1001010) ADDR -> SDA
- 0x4B (1001011) ADDR -> SCL

The ADDR should be connected to GND for the default address 0x48. **Do not leave it floating.** Might work, might not.

NAME	PIN	I/O	DESCRIPTION
A3	JP5 / 1	A	Differential channel 2: Negative Input or single-ended channel 4 input
A2	JP5 / 2	A	Differential channel 2: Positive Input or single-ended channel 3 input.
A1	JP5 / 3	A	Differential channel 1: Negative Input or single-ended channel 2 input. Connected to WindVane Input on JP1
A0	JP5 / 4	A	Differential channel 1: Positive Input or single-ended channel 1 input
ALRT	JP5 / 5	O	Digital comparator output or conversion ready
ADDR	JP5 / 6	I	I2C slave address select
SDA	JP5 / 7	I/O	Serial bus data line; open-drain input/output. No Pullup on WeatherPiArduino board.
SCL	JP5 / 8	I	Serial bus clock line; open-drain input. No Pullup on WeatherPiArduino board.
GND	JP5 / 9	A	GND
3V3	JP5 / 10	A	3.3V

**See JP8 for Internal ADS1015 Jumper Pin Connections**

## JP6 - Optional Non-Volatile FRAM

The MB85RC256V is a 256K-bits FRAM with serial interface (I2C), using the ferroelectric process and CMOS process technologies for forming the nonvolatile memory cells. A FRAM is able to write high-speed even though it is a nonvolatile memory. The optional FRAM module is much faster to read and write to than the included EEPROM device.

It is suitable for the log management and the storage of the resume data, etc. Project Curacao ([www.switchdoc.com](http://www.switchdoc.com)) uses it to record Weather data during the night when the Raspberry Pi is not powered up. Each byte can be read and written instantaneously (like SRAM) but will keep the memory for 95 years at room temperature. Each byte can be read/written 10,000,000,000,000 times.

NAME	PIN	I/O	DESCRIPTION
3V3	JP6 / 1	A	3.3V
GND	JP6 / 2	A	GND
WP	JP6 / 3	I	Write Protect pin. This is used to force write protection so you cannot write to the FRAM. It has an internal pulldown. Bring to a high voltage (VCC) to turn on WP
SCL	JP6 / 4	I	Serial bus clock line; open-drain input. No Pullup on WeatherPiArduino board.
SDA	JP6 / 5	I/O	Serial bus data line; open-drain input/output. No Pullup on WeatherPiArduino board
A2	JP6 / 6	I	High selection bit (use A2,A1,A0 as three bits and add to 0x50)
A1	JP6 / 7	I	Middle selection bit (use A2,A1,A0 as three bits and add to 0x50)
A0	JP7 / 8	I	Low selection bit (use A2,A1,A0 as three bits and add to 0x50)

## JP3 - Optional FRAM Address

Used to set other I2C addresses for the Optional I2C FRAM Module. These are the I2C address selection pins. By default the I2C address is 0x50. Connecting these pins to 3V3 and power cycling the chip will adjust the lower three bits of the address. For example, if A0 is high, the address is 0x51. If A1 and A2 are high, the address is 0x56

NAME	PIN	I/O	DESCRIPTION
A2	JP3 / 1	I	High selection bit (use A2,A1,A0 as three bits and add to 0x50)
A1	JP3 / 2	I	Middle selection bit (use A2,A1,A0 as three bits and add to 0x50)
A0	JP3 / 3	I	Low selection bit (use A2,A1,A0 as three bits and add to 0x50)

## JP8 - Optional A/D Inputs for Optional ADS1015 ADC

**NOTE:** On the WeatherPiArduino version 0010-122314-01 the Silkscreen is offset by one pin because of the mounting holes.

Connect up external A/D Inputs using this header. The ADS1015 chips have a base 7-bit I2C address of 0x48 and an addressing scheme that allows four different addresses using just one address pin. To program the address, connect the address pin as follows:

- 0x48 (1001000) ADDR -> GND
- 0x49 (1001001) ADDR -> VDD
- 0x4A (1001010) ADDR -> SDA
- 0x4B (1001011) ADDR -> SCL

The ADDR should be connected to GND for the default address 0x48. **Do not leave it floating.**

NAME	PIN	I/O	DESCRIPTION
ADDR	JP8 / 1	I	I2C slave address select
ALRT	JP8 / 2	O	Digital comparator output or conversion ready
A3	JP8 / 3	A	Differential channel 2: Negative Input or single-ended channel 4 input
A2	JP8 / 4	A	Differential channel 2: Positive Input or single-ended channel 3 input.
A1	JP8 / 5	A	Differential channel 1: Negative Input or single-ended channel 2 input. Connected to WindVane Input on JP1
A0	JP8 / 6	A	Differential channel 1: Positive Input or single-ended channel 1 input

## JP10 - I2C for Arduino

This is a 5V I2C bus for use by the Arduino. **Not a 3.3V I2C bus.** Use JP4 to connect 3.3V SCL and SDA from the Raspberry Pi.

NAME	PIN	I/O	DESCRIPTION
SCL	JP10 / 1	I	5V Tolerant Serial bus clock line; open-drain input. No Pullup on board
SDA	JP10 / 2	I/O	5V Tolerant Serial bus data line; open-drain input/output. No Pullup on board



## JP11 - Included DS3231/EEPROM Real Time Clock and Storage

The DS3231 is a low-cost, extremely accurate I<sup>2</sup>C real-time clock (RTC) with an integrated temperature-compensated crystal oscillator (TCXO) and crystal. The device incorporates a battery input, and maintains accurate timekeeping when main power to the device is interrupted. This is included with the WeatherPiArduino Board. **Note: when installing the DS3231 board bend the pins of J10 to a 45 degree angle away from the DS3231 board to allow those pins to be used and minimize the problem of shorting.**

NAME	PIN	I/O	DESCRIPTION
32K	JP11 / 1	O	32kHz Output. This open-drain pin requires an external pullup resistor to 3V3. When enabled, the output operates on either power supply. It may be left open if not used.
SQW	JP11 / 2	O	Active-Low Interrupt or Square-Wave Output. This open-drain pin requires an external pullup resistor to 3V3. It may be left open if not used.
SCL	JP11 / 3	I	Serial bus clock line; open-drain input. No Pullup on WeatherPiArduino board.
SDA	JP12 / 4	I/O	Serial bus data line; open-drain input/output. No Pullup on WeatherPiArduino board
3V3	JP12 / 5	A	Connected to 3V3 (3.3V)
GND	JP12 / 5	A	GND

## JP12 - Optional Lightning Detector - MOD-1016

The MOD-1016 (Embedded Adventures) is an AS3935 based lightning and storm sensor. It comes pre-calibrated, meaning that you don't have to write complex frequency calculation code, you can simply program the correct calibration details and get cracking finding storms. The AS3935 is a programmable fully integrated Lightning Sensor IC that detects the presence and approach of potentially hazardous lightning activity in the vicinity and provides an estimation on the distance to the head of the storm. The embedded lightning algorithm checks the incoming signal pattern to reject the potential man-made disturbers.

The AS3935 can also provide information on the noise level and inform the external unit (e.g. microcontroller) in case of high noise conditions, with the noise floor generator and noise floor evaluation blocks.

NAME	PIN	I/O	DESCRIPTION
3V3	JP12 / 1	A	Connected to 3V3 (3.3V)
CS	JP12 / 2	I	N/C
IRQ	JP12 / 3	O	Interrupt request from the AS3935
SCL	JP12 / 4	I	Serial bus clock line; open-drain input. No Pullup on WeatherPiArduino board.
MISO	JP12 / 5	I	N/C
SDA	JP12 / 6	I/O	Serial bus data line; open-drain input/output. No Pullup on WeatherPiArduino board
GND	JP12 / 7	A	GND

### JP13 - Interrupt From Optional Lightning Detector

See AS3935 Specification for information.

NAME	PIN	I/O	DESCRIPTION
LD-IRQ	JP13 / 1	A	Interrupt request from the AS3935 from Lightning Detector Board

### JP14 - Optional HTU21D-F Humidity/Temperature Sensor

This I2C digital humidity sensor has a typical accuracy of  $\pm 2\%$  with an operating range that's optimized from 5% to 95% RH. HTU21D(F) digital humidity sensors are dedicated humidity and temperature plug and play transducers.

Every sensor is individually calibrated and tested. Lot identification is printed on the sensor and an electronic identification code is stored on the chip – which can be read out by command. Low battery can be detected and a checksum improves communication reliability. The resolution of these digital humidity sensors can be changed by command (8/12bit up to 12/14bit for RH/T).

NAME	PIN	I/O	DESCRIPTION
VIN	JP15 / 1	A	Connected to 3V3 (3.3V)
3V3		A	N/C (3V3 Output - not used in WeatherPiArduino)
SDA	JP12 / 5	I/O	Serial bus data line; open-drain input/output. No Pullup on WeatherPiArduino board
SCL	JP12 / 4	I	Serial bus clock line; open-drain input. No Pullup on WeatherPiArduino board.
GND	JP15 / 3	A	GND

## I2CPULL - Optional Additional Pullups on I2C (SCL/SDA)

These two pin hole through resistors are used if you determine you want additional pull-ups (to 3V3) on the I2C bus.

## Example Applications

The following diagrams show how to hook up a WeatherPiArduino board to the WeatherRack Anemometer, WindVane and RainBucket and the Raspberry Pi or Arduino.

## Connecting an Arduino Mega 2560 to the WeatherPiArduino Board

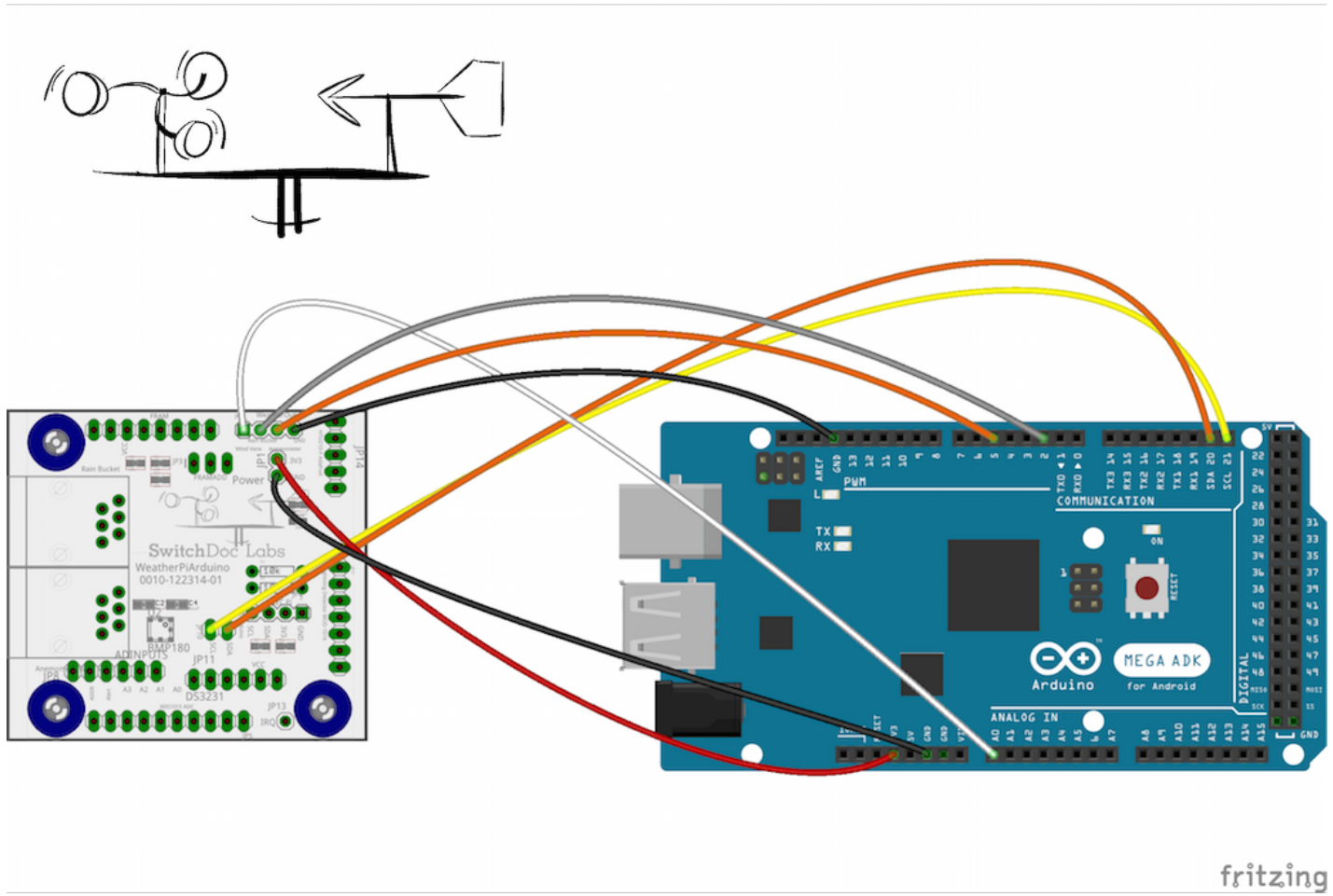

fritzing

## Connecting an Arduino Uno to the WeatherPiArduino Board

Notes: The Arduino series has a built in Analog Digital Converter (ADC). The Atmega controllers used for

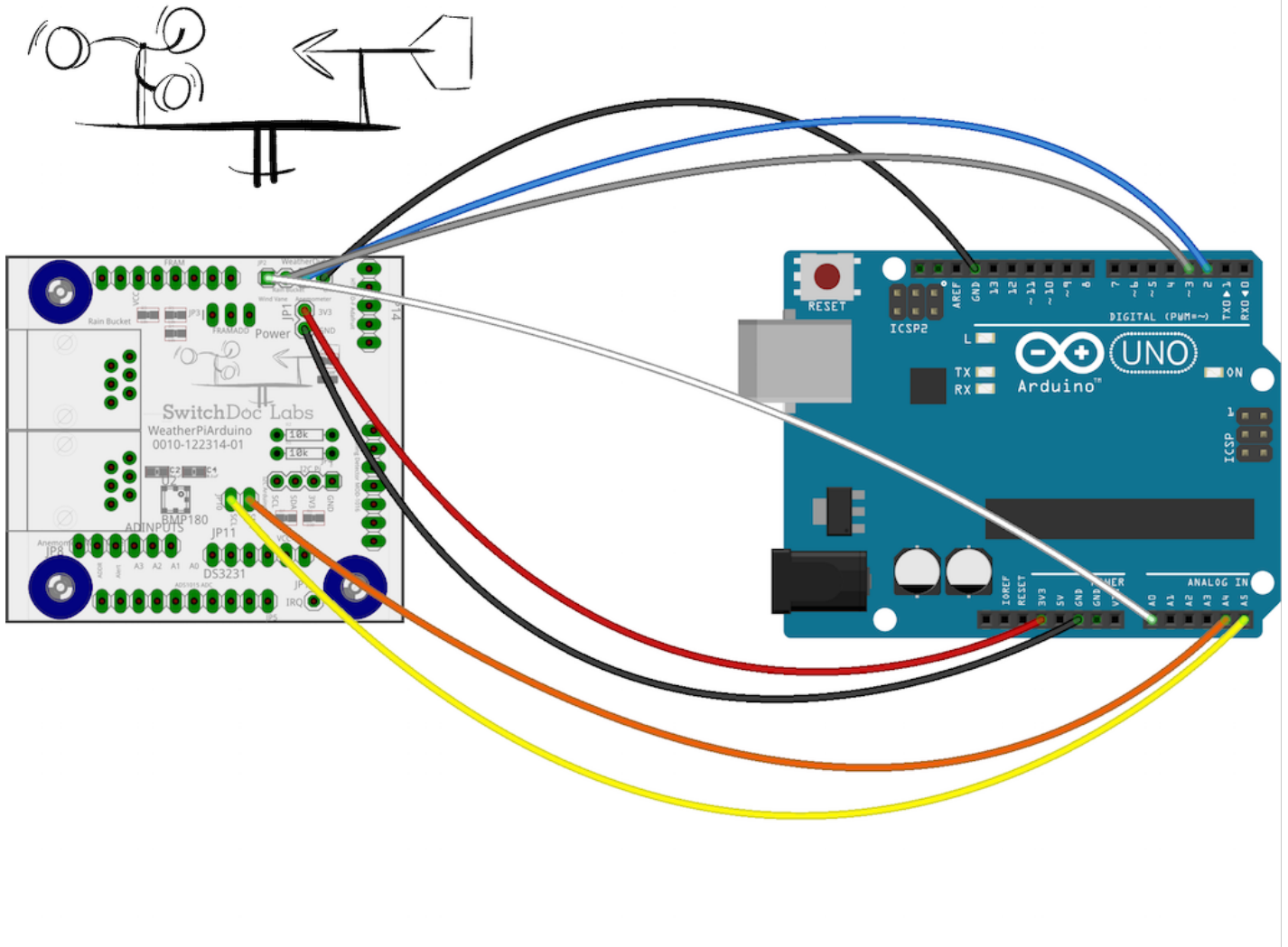

The Arduino contain an onboard 6 channel analog-to-digital (A/D) converter. The converter has 10 bit resolution, returning integers from 0 to 1024. The Arduino ADC does have some issues with accuracy and sample speed. If you have a long cable running to the WeatherRack sensors (Wind Vane especially), you will have issues reading the correct wind direction (as well as noise issues. If you have noise issues, bypass the Wind Vane line with 0.1uF bypass capacitors to ground.).

The WeatherPiArduino board has a slot and pinouts to support an Adafruit ADS1015 which is an excellent inexpensive ADC. The ADS1015 provides 12-bit precision at 3300 samples/second over I2C. The chip can be configured as 4 single-ended input channels, or two differential channels. As a nice bonus, it even includes a programmable gain

amplifier, up to x16, to help boost up smaller single/differential signals to the full range. We like this ADC because, can measure a large range of signals and its super easy to use. It is a great general purpose 12 bit converter.

## Connecting a Raspberry Pi B+ to the Dual WatchDog Board

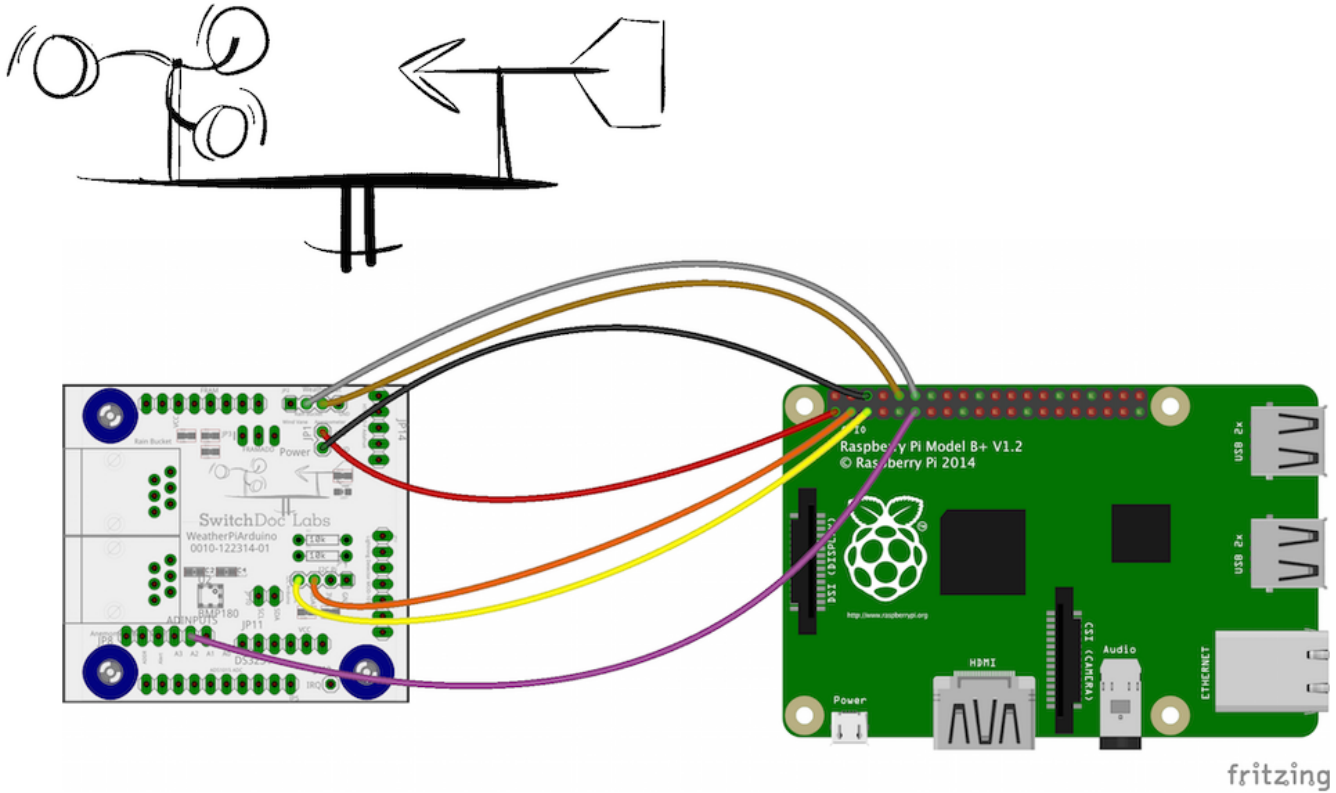

Notes: The Raspberry Pi does not have a built in Analog Digital converter (like the Arduino). The WeatherPiArduino board has a slot and pinouts to support an Adafruit ADS1015 which is an excellent inexpensive ADC. The ADS1015 provides 12-bit precision at 3300 samples/second over I2C. The chip can be configured as 4 single-ended input channels, or two differential channels. As a nice bonus, it even includes a programmable gain amplifier, up to x16, to help boost up smaller single/differential signals to the full range. This ADC can measure a large range of signals and its super easy to use. It is a great general purpose 12 bit converter.

## Control Panels

Special versions of RasPiConnect and ArduinoConnect for the WeatherPiArduino will be available for \$3.00 on the Apple Appstore in February of 2015. The control panel for the WeatherPiArduino is shown below.

SwitchDoc Labs has completed a licensing agreement with [MiloCreek](http://www.milocreek.com) ([www.milocreek.com](http://www.milocreek.com)) to put a version of RasPiConnect and ArduinoConnect up on the Appstore for WeatherPiArduino customers. These will be sold by MiloCreek and will be called WeatherPiConnect and WeatherArduinoConnect.

