

SwitchDoc Labs

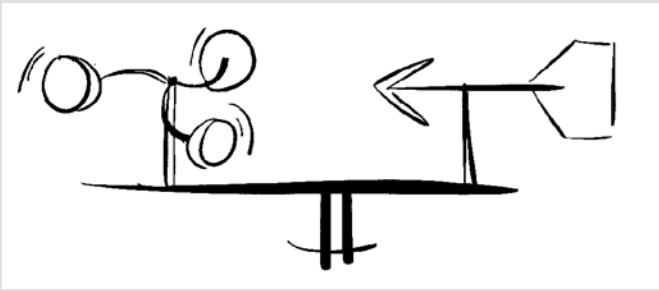

The **WeatherPlus Board** is an stand alone and interface board for connecting a full featured, customizable board for Raspberry Pi and Arduino projects with an on-board ESP8266 WiFi. It contains a built in I2C ADS1015 ADC and a BMP280 Barometer/ Temperature sensor and contains interfaces for the following:

- DS3231 RTC
- SwitchDoc Labs WeatherRack Anemometer/Wind Vane/Rain Bucket
- Grove Compatible I2C Plug for additional sensors such as the SwitchDoc Labs Grove AM2315 Outside Temp/Humidity Sensor
- Embedded Adventures I2C Lightning Detector MOD-1016 board
- Adafruit 32KB FRAM I2C breakout board

Features and Benefits:

- Provides an excellent controller for a Weather Station hooked up to Raspberry Pi or Arduino
- Includes Arduino and Raspberry Pi Software
- Supports SwitchDoc Labs WeatherRack Wind Vane / Anemometer / Rain Bucket
- Contains I2C BMP280 Barometer/Temperature
- Included DS3231 RTC/EEPROM
- Directly powers Raspberry Pi / Arduino
- Works with Raspberry Pi (3.3V) GPIO and Arduino (5.0V) GPIO
- Works with 3.3V and 5.0V I2C bus
- All onboard devices are 3.3V
- Supports I2C Lightning Detector MOD-1016
- Supports I2C AM2315 Temp/Hum Sensor
- Supports I2C Optional 32KB FRAM
- Low Cost
- Full Test Code Supplied
- Quantity Discounts Available
- Immediate Availability

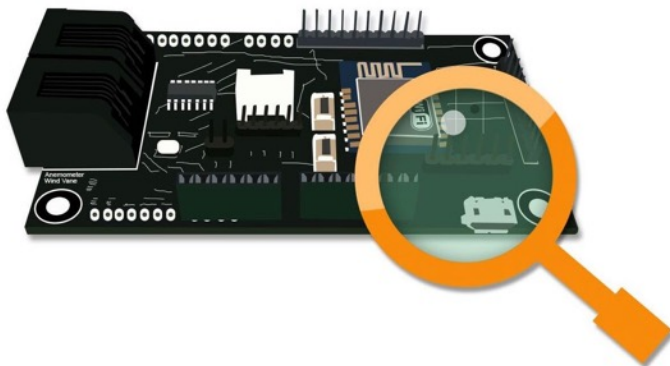

Introduction

WeatherPlus is a complete weather station controller board designed to interface to Arduino and Raspberry Pi computers. It contains a full Arduino Compatible ESP8266 Wifi computer and can run stand-alone or with a Raspberry Pi or Arduino.

Combine the WeatherPlus with a SunAir or SunAirPlus board to create a solar powered weather station. Additional code and examples on www.switchdoc.com on the WeatherPlus Product Page

SwitchDoc Labs

Block Diagram



WeatherPlus

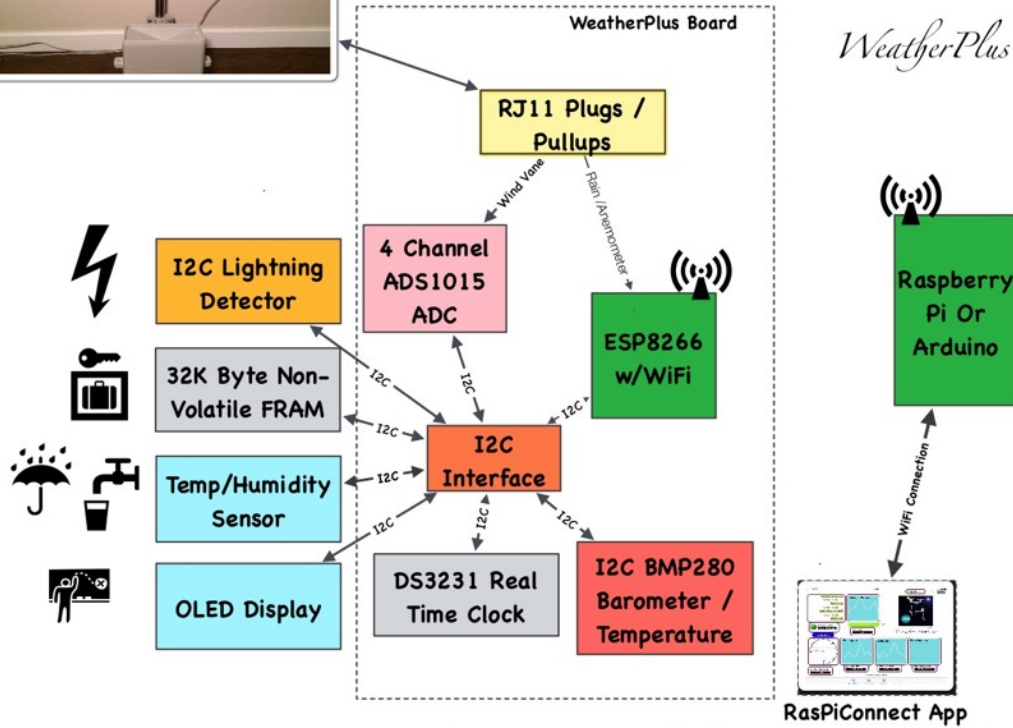

SwitchDoc Labs

SwitchDoc Labs

Differences from WeatherPlus R1 to WeatherPlus R2 boards

Both boards are software compatible with the OurWeather software.

Rev1 Boards (marked 0011-121415-01) have a BMP180 and one Grove I2C connector

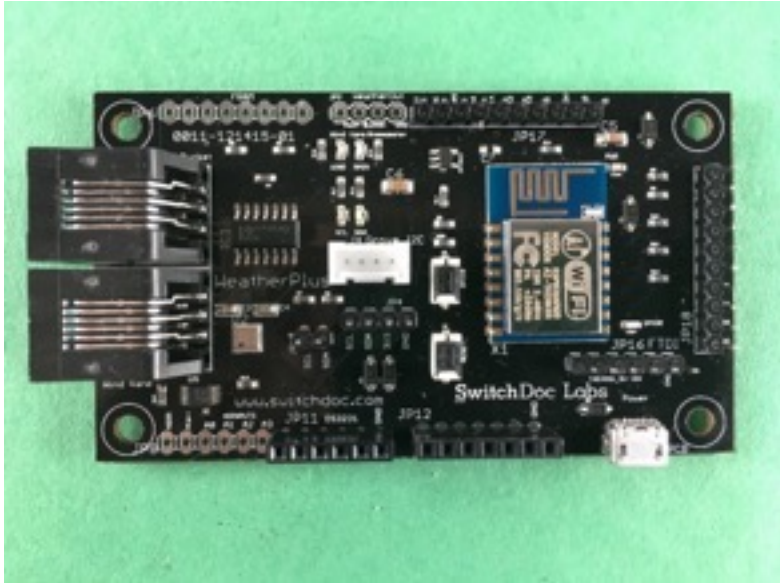

Rev 2 Boards (marked 0011-021916-01) contain a BMP280 and two Grove I2C Connectors

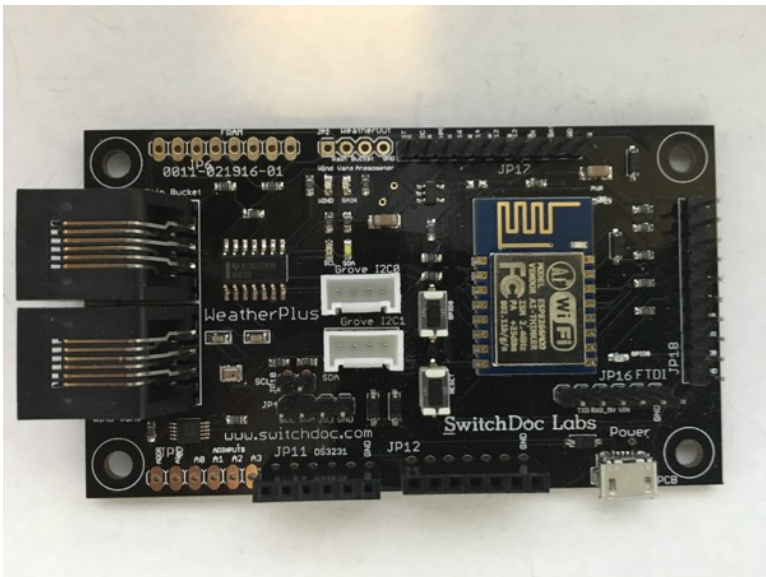

SwitchDoc Labs

Theory of Operation

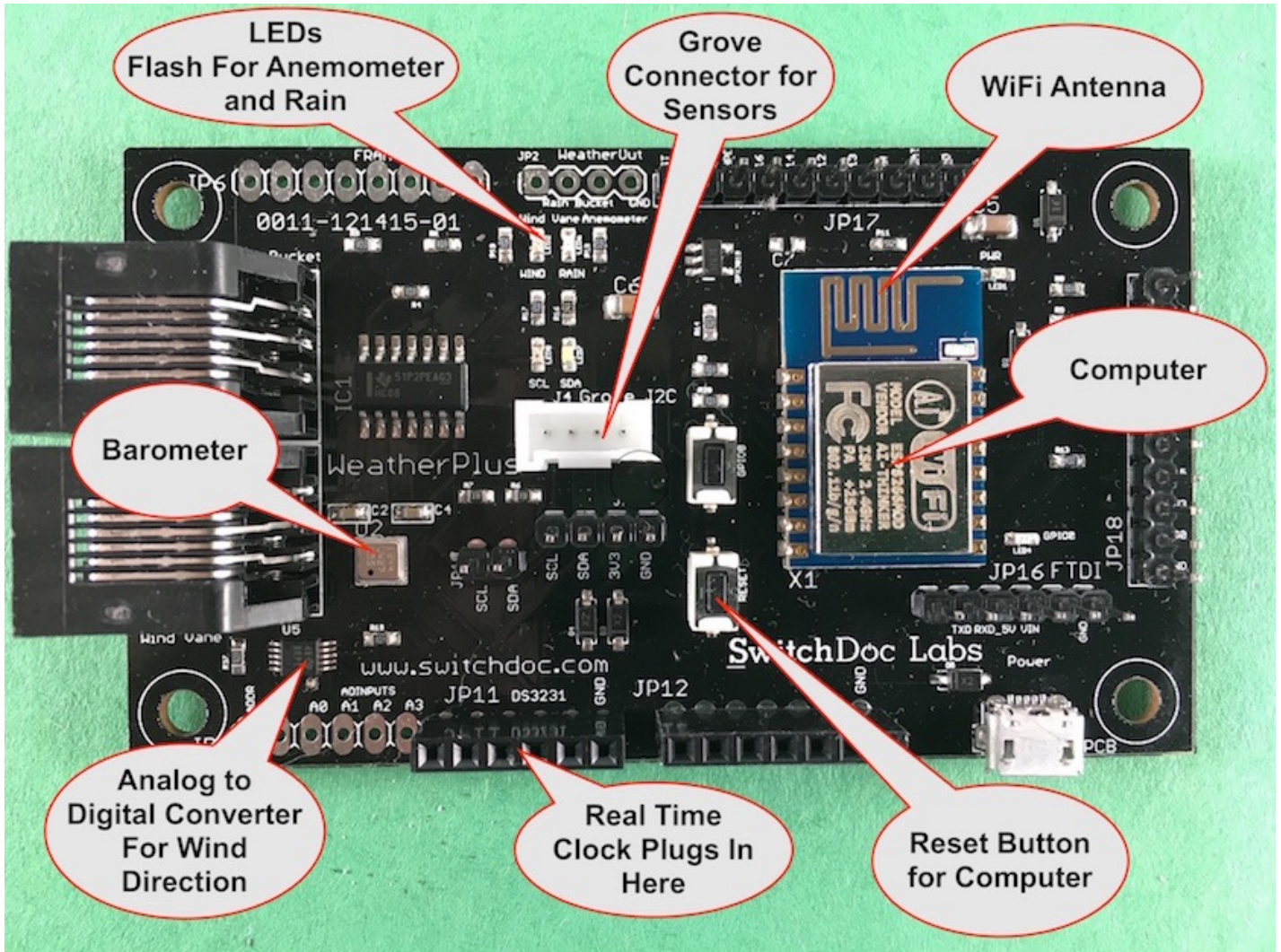

Software

Software and drivers for the WeatherPlus boards can be located on the SwitchDoc Labs WeatherPlus product page (www.switchdoc.com).

ESP8266 w/WiFi

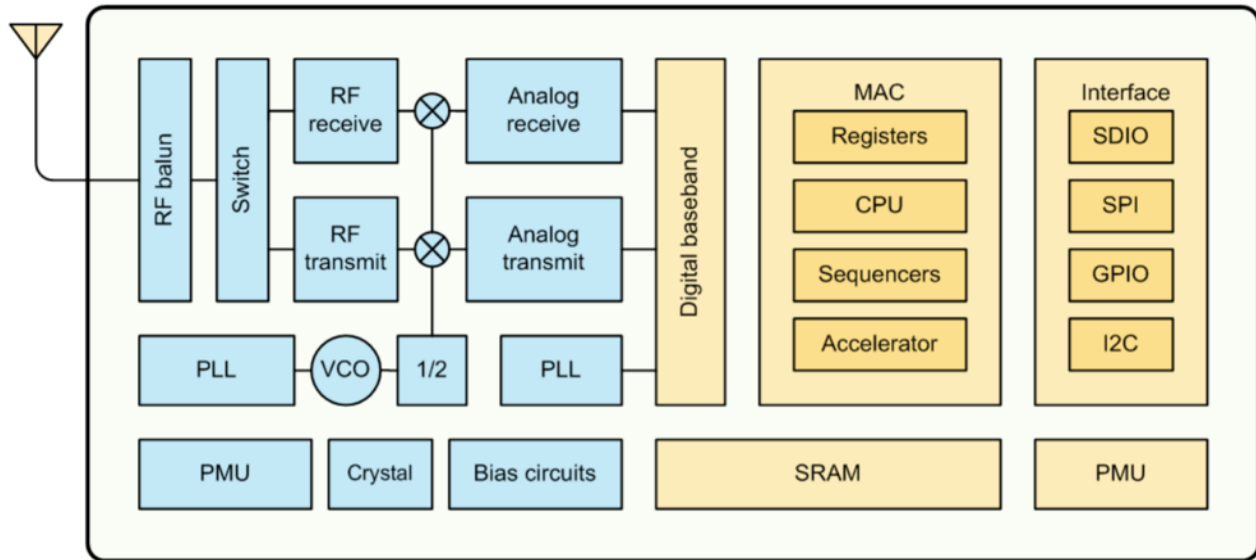

The heart of the WeatherPlus board is an ESP8266-12 Module. It contains an Arduino IDE Compatible CPU, 4Mbytes of program flash and over 80K bytes of usable RAM. The firmware implements a full WiFi interface compatible with most routers.

While there are many firmware options for the EPS8266 available, SwitchDoc Labs uses the Arduino IDE and Arduino libraries to provide the best experience and functionality to WeathePlus users.

RJ11 Plugs / Pullups

The RJ11 Plugs on the WeatherPlus are designed to hook into inexpensive Anemometers, Wind Vanes and Rain Buckets. These plugs are wired to directly support the plugs coming from:

- SwitchDoc Labs WeatherRack (<http://www.switchdoc.com/weatherrack-weather-sensors/>). Available on the SwitchDoc Store and on Amazon.
- ArgentData (<http://www.argentdata.com>)
- SparkFun (<http://www.sparkfun.com>)

SwitchDoc Labs

I2C Interface

The I2C interface has two parts. There are two Grove I2C connectors on the WeatherPlus Boards. These are 3.3V I2C Grove connectors. More about Grove Connectors on www.switchdoc.com. Note that you can plug these into a Raspberry Pi. If you do, make sure that the on board ESP8266 is not also accessing the I2C Bus (this is easy to do with the Arduino IDE and an FTDI cable to program the Weather Plus board).

JP10 contains the interface from an external Arduino. It provides voltage protection for the WeatherPlus devices from the 5V signals from the Arduino. The pins are connected in series to a 330 Ohm resistor to drop the voltage.

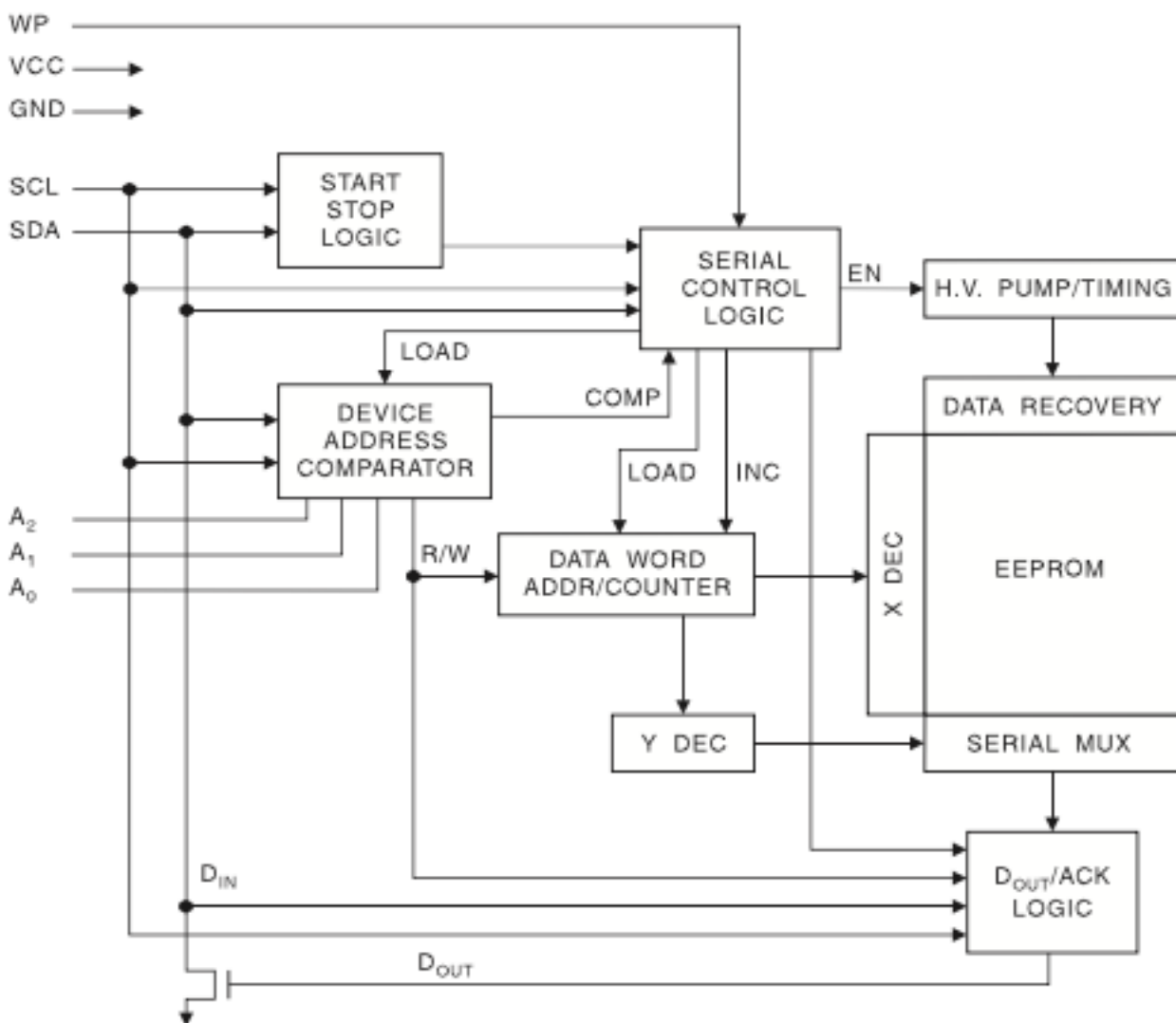

SwitchDoc Labs

BMP280 Barometer / Temperature

The WeatherPlus board has an on board BMP280 Barometer / Temperature sensor connected to the I2C bus from the computer. The BMP280 is the functionally compatible successor of the BMP085 and BMP180 (the BMP180 is present on some early WeatherPlus R1 Boards).

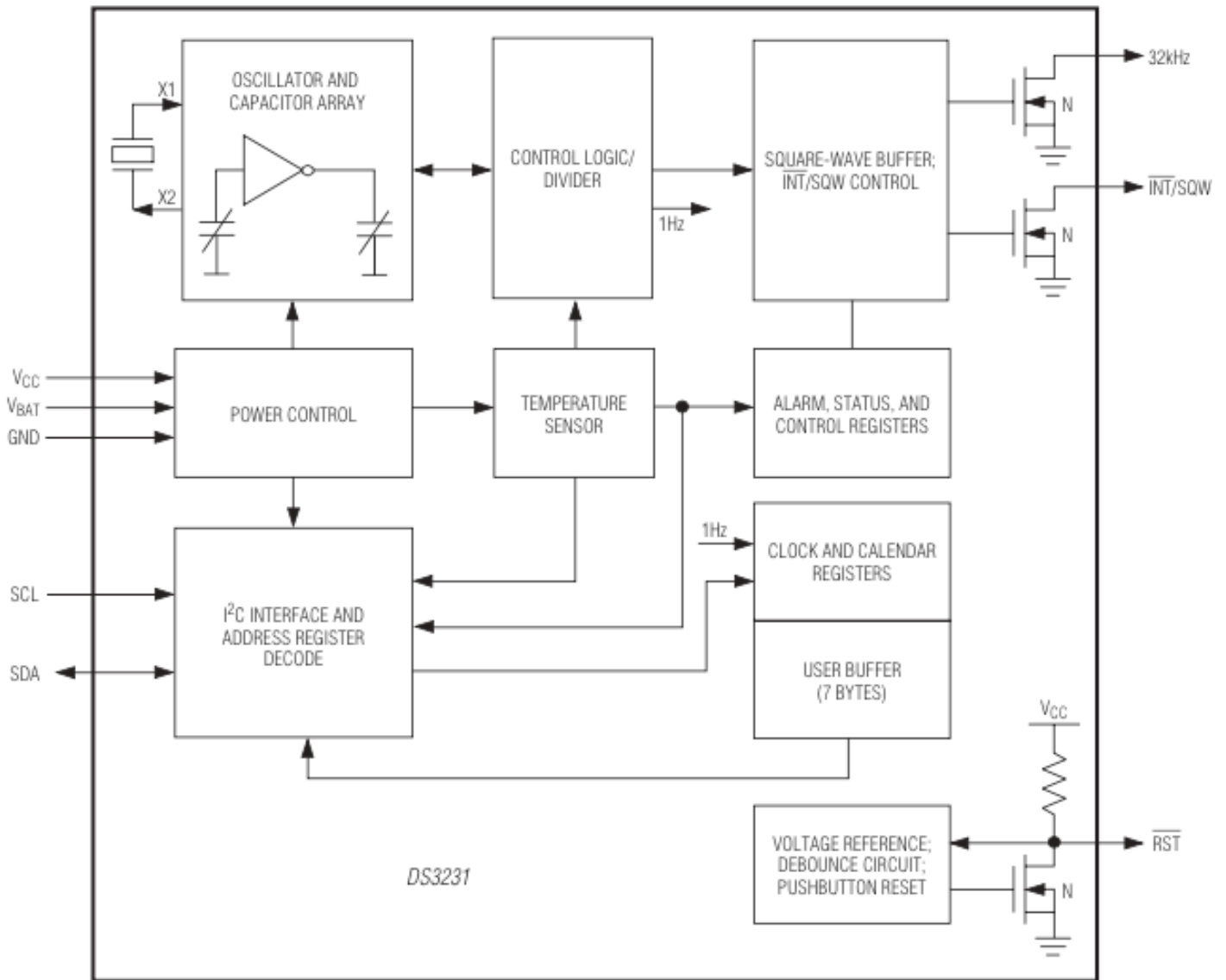

With a low altitude noise of merely 0.25m at fast conversion time, the BMP280 offers superior performance. The BMP280 is based on piezo-resistive technology for EMC robustness, high accuracy and linearity as well

SwitchDoc Labs

as long term stability. The BMP280 consists of a piezo-resistive sensor, an analog to digital converter and a control unit with EEPROM and a serial I2C interface. The BMP280 delivers the uncompensated value of pressure and Temperature. Pressure data is 16 to 19 bits and temperature data is 16 bits. The resolution of the barometer is 0.16Pa and the temperature sensor is 0.01C.

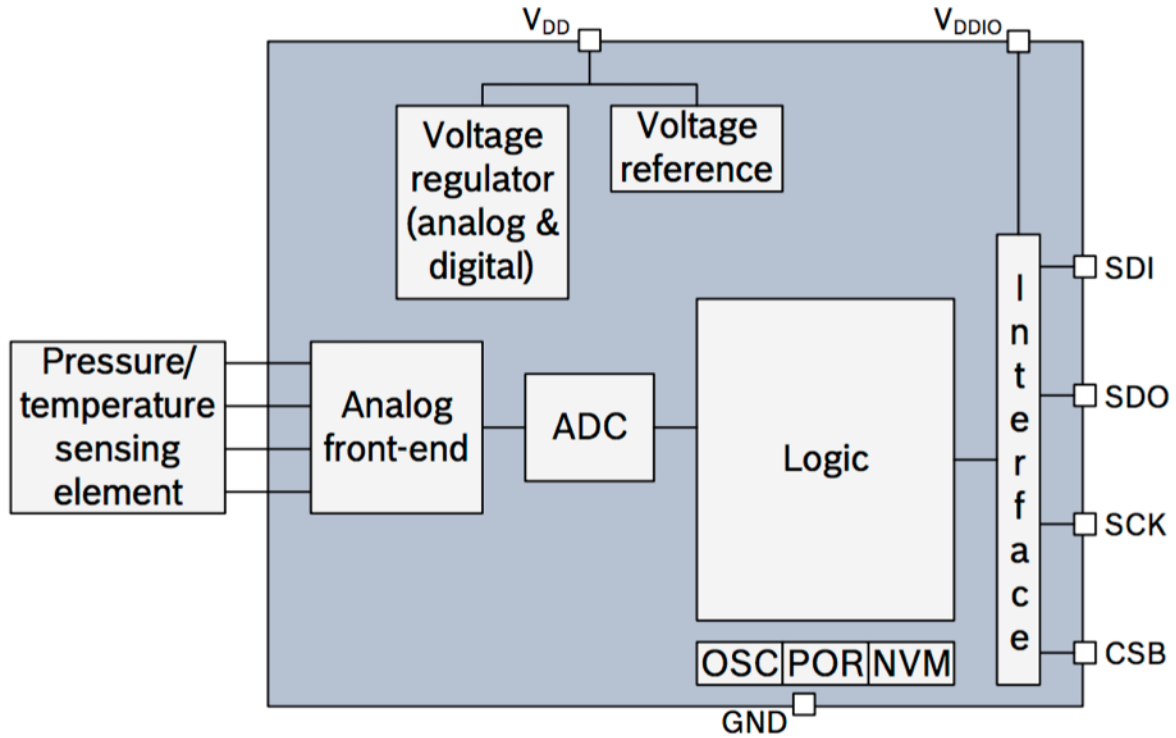

The BMP280 as shown above is a high precision I2C Barometer / Temperature sensor. Older WeatherPlus board (before revision 0011-021916-01) have the BMP180, the previous member of this family.

The specifications for this device is on the SwitchDoc Labs WeatherPlus product page.

DS3231/EEPROM Real Time Clock

The SwitchDoc Labs DS3231/EEPROM combination is included with the WeatherPlus board. It is plugged in by the user into JP11, taking care to having the battery facing the top of the board with the GNDs aligned.

The DS3231 is a low-cost, extremely accurate I²C real-time clock (RTC) with an integrated temperature-compensated crystal oscillator (TCXO) and crystal. The device incorporates a battery input, and maintains accurate timekeeping when main power to the device is interrupted. The integration of the crystal resonator enhances the long-term accuracy of the device.

The RTC maintains seconds, minutes, hours, day, date, month, and year information. The date at the end of the month is automatically adjusted for months with fewer than 31 days, including corrections for leap year. The clock operates in either the 24-hour or 12-hour format with an AM/PM indicator. Two programmable time-of-day alarms and a programmable square-wave output are provided. Address and data are transferred serially through the I²C bidirectional bus.

A precision temperature-compensated voltage reference and comparator circuit monitors the status of 3V3 to detect power failures, to provide a reset output, and to automatically switch to the backup supply (battery included) when necessary.

The specification for this device is on the SwitchDoc Labs WeatherPlus product page.

AT24C32 32KB EEPROM

The AT24C32 provides 32,768 bits of serial electrically erasable and programmable read only memory (EEPROM) organized as 4096 words of 8 bits each. The EEPROM drivers are included in the SwitchDoc driver software.

ADS1015 4 Channel ADC

WeatherPlus contains an excellent built-in 12 bit 4 channel A/D converter an I²C device known as the ADS1015. The ADS1015 is a precision analog-to-digital converter (ADC) with 12 bits of resolution. The ADS1015 features an onboard reference and oscillator. Data are transferred via an I²C-compatible serial interface; four I²C slave addresses can be selected.

The ADS1015 can perform conversions at rates up to 3300 samples per second (SPS). An onboard PGA is available on the ADS1015 that offers input ranges from the supply to as low as $\pm 256\text{mV}$,

SwitchDoc Labs

allowing both large and small signals to be measured with high resolution. The ADS1015 also features an input multiplexer (MUX) that provides two differential or four single-ended inputs.

The ADS1015 operates either in continuous conversion mode or a single-shot mode that automatically powers down after a conversion and greatly reduces current consumption during idle periods.

Software for the ADS1015 for both the Raspberry Pi and Arduino is readily available from Adafruit and others.

The Default I2C address is 0x49. If you have more than one 0x49 address in your system, consider using a SwitchDoc Labs I2C 4 channel Mux to avoid address conflicts.

WeatherPlus Sensor Compatibility

The anemometer and rain bucket pins are pulled to 3.3V via a 10K Ohm pullup resistor. These are intended to connect to interrupt inputs on the host computer.

The standard Anemometer in these devices measures wind speed by closing a contact as a magnet moves past a switch. One contact closure a second indicates 1.492 MPH (2.4 km/h). If you use a different anemometer, this constant can be changed in software.

The tipping bucket Rain Gauge is used the SwitchDoc Labs WeatherRack, the SparkFun Weather Sensor and the ArgentData Sensors. The standard rain gauge used in these devices makes one momentary contact closure that can be recorded with a micro controller interrupt input. Each contact closure of the standard unit indicates 0.011 inch (0.2794 mm). If you use a different tipping rain gauge you can adjust these values in software.

The Wind vane has 8 switches, each connected to a different resistor. The WeatherPlus measures the resistance value of the resistor by measuring the voltage on a resistor divider (with 10K Ohm onboard resistor). With a WeatherPlus board, it is measured either with the on-board ADS1015. See the SwitchDoc Labs WeatherRack Product Specification for more information on the Wind Vane.

See the SwitchDoc Labs drivers provided on www.switchdoc.com.

Note that most RJ11 cables only have 4 wires instead of the six allowed by the plug.

The specifications for this device is on the SwitchDoc Labs WeatherPlus product page.

Default I2C Addresses

The default I2C addresses for the on board devices and the optional devices are shown below.

DEVICE	DESCRIPTION	HEX ADDRESS	COMMENTS
BMP280	Barometer / Temperature	0x77	Included
DS3231	Real Time Clock	0x68	Included
AT24C32	EEPROM	0x56	Included
ADS1015	ADC	0x49	Included
MOD-1016	Lightning Detector	0x03	Optional Board.
Grove AM2315	Encased Temp/ Humidity Sensor	0x5C	Optional Fixed I2C Address. See the SwitchDoc Labs page for more information.
FRAM	32KB FRAM	0x50	Optional Board. Can change I2C Addresses.

External Modules

There are a number of sources of each one of these external modules. If you do choose to use an alternative source of boards, make sure that you are connecting to the correct pins. The pinouts on WeatherPlus are set up for the following modules.

- Embedded Adventures MOD-1016 Lightning Detector - detect nearby and far away lightning storms
- Grove AM2315 SwitchDoc Labs - Encased (weather resistant) Temperature and Humidity Sensor
- Adafruit 32KB FRAM - very fast non-volatile RAM

The specifications for all of these devices are on the SwitchDoc Labs WeatherPlus product page.

SwitchDoc Labs

Operating Values

	Min	Normal	Max	Unit
3V3	3.313V	3.3V	3.465	V

*WeatherPlus Power Consumption depends on what other devices you have added to the board.

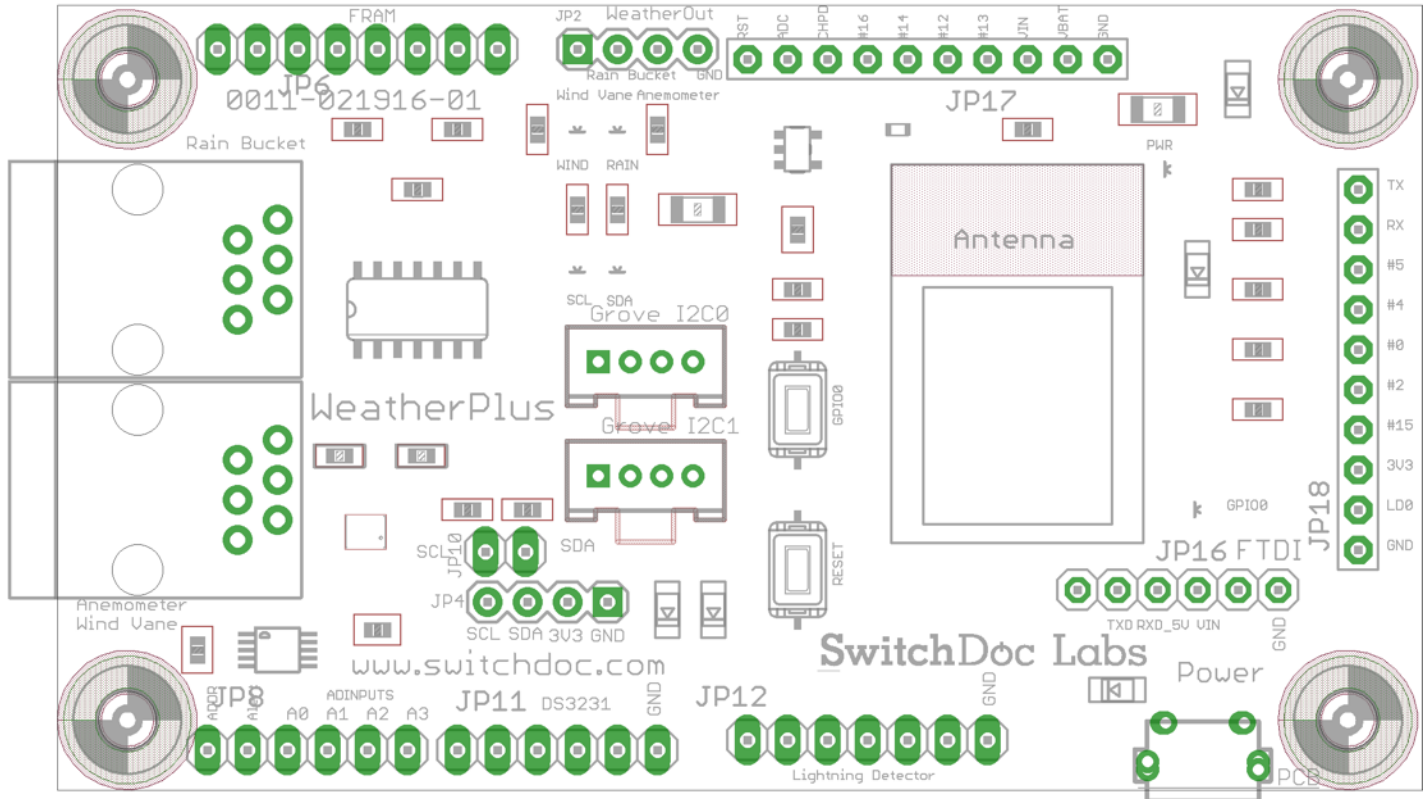

WeatherPlus Board Jumper Pin and Plug Locations

Physical dimensions of board: 89mm x 50mm x 14.5mm(max). Mounting holes inset 3.8mm x 3.8mm from each corner to center of hole. Diameter of hole 2mm.

I/O Key:

SwitchDoc Labs

I - Digital Input
O - Digital Output
A - Analog

LED Displays

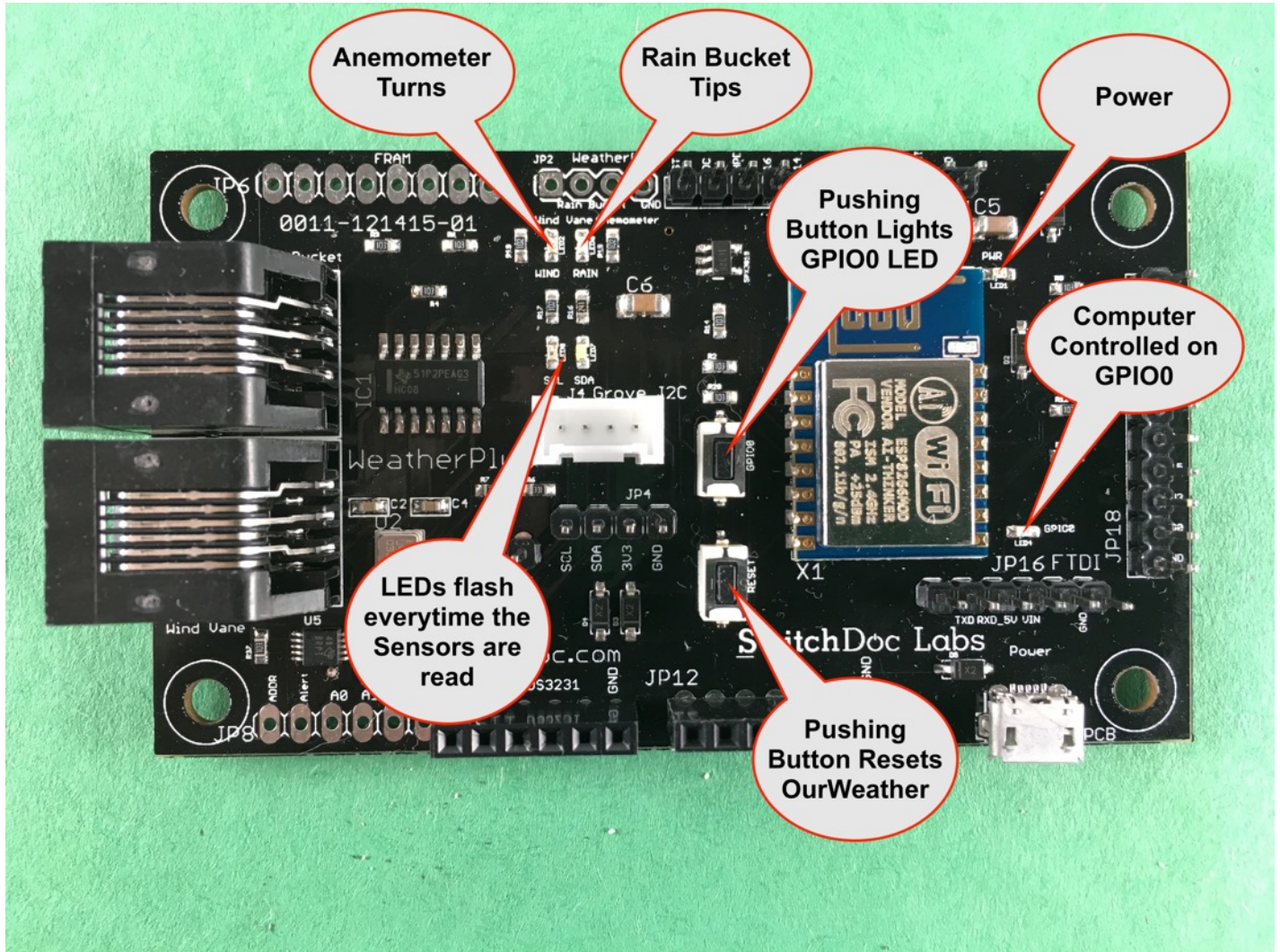

You can also pulse the blue LED next to the WiFi antenna by writing to GPIO 2.

Push Button Switch Functions

GPIO0 Push Button

This push button switch is connected to a red LED. This pin is used by the ESP8266 to determine when to boot into the bootloader. If the pin is held low during power-up it will start bootloading! See the programming procedure below.

RESET Push Button

Pushing this button resets the ESP8266 and restarts the sketch.

Arduino IDE

In order to install the Arduino IDE with support for the ESP8266 on the WeatherPlus board, please follow the excellent Adafruit tutorial here:

<https://learn.adafruit.com/adafruit-huzzah-esp8266-breakout/using-arduino-ide>

Programming Sequence

In order to upload code to the ESP8266 and use the serial console, you will need a 3.3V FTDI cable. SwitchDoc Labs sells an inexpensive cable that is both 3.3V and 5.0V jumper selectable.

<http://www.switchdoc.com/inexpensive-ftdi-cable-for-arduino-esp8266-includes-usb-cable/>

Do this to put the board into bootload mode. You'll have to do this before each upload from the Arduino IDE.

1. Hold down the GPIO0 button, the red LED will be lit
2. While holding down GPIO0, click the RESET button
3. Release RESET, then release GPIO0
4. When you release the RESET button, the red GPIO0 LED will be lit dimly, this means its ready to bootload

Once the WeatherPlus board is in bootload mode, upload the sketch via the Arduino IDE.

Plug Functions

J1 - Anemometer / Wind Vane RJ11 Plug

SwitchDoc Labs

Used to connect the WeatherPiArduino board to a wind vane and anemometer such as used in the SwitchDoc Labs WeatherRack, the SparkFun Weather Sensor and the ArgentData Sensors. The standard Anemometer in these devices measures wind speed by closing a contact as a magnet moves past a switch. One contact closure a second indicates 1.492 MPH (2.4 km/h). If you use a different anemometer, this constant can be changed in software. The Wind vane has 8 switches, each connected to a different resistor. The WeatherPlus measures the resistance value of the resistor by measuring the voltage on a resistor divider (with 10 K Ohm resistor). With an Arduino, it is measured either with the optional ADS1015 or the internal A/D converters. In the case of a Raspberry Pi measuring this voltage requires an external A/D converter such as the ADS1015. See the SwitchDoc Labs WeatherRack Product Specification for more information on the Wind Vane.

NAME	PIN	I/O	DESCRIPTION
N/C	J1 / 1		No Connection
GND	J1 / 2	A	Connected to GND
GND	J1 / 3	A	Connected to GND
Anemometer	J1 / 4	A	Connected to Anemometer pin on JP2 and 10K Ohm Pullup to 3V3
Wind Vane	J1 / 5	A	Connected to Wind Vane Pin on JP2 and also to ADC-A1 on JP5 and JP8 for use by the optional ADS1015 ADC and 10K Ohm Pullup to 3V3
N/C	J1 / 6		No Connection

J2 - Rain Bucket RJ11 Plug

Used to connect the WeatherPlus to a tipping bucket Rain Gauge used in the SwitchDoc Labs WeatherRack, the SparkFun Weather Sensor and the ArgentData Sensors. The standard rain gauge used in these devices makes one momentary contact closure that can be recorded with a micro controller interrupt input. Each contact closure of the standard unit indicates 0.011 inch (0.2794 mm). If you use a different tipping rain gauge you can adjust these values in software.

Note that most RJ11 cables only have 4 wires instead of the six allowed by the plug.

NAME	PIN	I/O	DESCRIPTION
N/C	J2 / 1		No Connection
N/C	J2 / 2		No Connection
GND	J2 / 3	A	Connected to GND
RainBucket Contact	J2 / 4	A	Connected to Rain Gauge ping on JP2 and 10K Ohm Pullup to 3V3
N/C	J2 / 5		No Connection
N/C	J2 / 6		No Connection

SwitchDoc Labs

Jumper Pin Functions

JP1 - Power

This is a MicroUSB plug used to supply 5V power to the WeatherPlus board. There is an onboard 3.3V regulator.

JP16 - FTDI Connector (3.3V FTDI only!)

Note: Pin 6 is marked GND

NAME	PIN	I/O	DESCRIPTION
N/C	J16/ 1		No Connection
TX	J16/ 2	O	Serial Output - Connected to TX pin on JP18)
RX	J16/ 3	I	Serial Input (NOT 5.0V Compatible!!!!) - Connected to RX pin on JP18
VIN	J16/ 4	A	Maximum 20V. Schottky Diode protected. The board will take the power from VIN or VBAT whichever is highest voltage.
N/C	J16/ 5		No Connection
GND	J16/ 6	A	Ground

JP17 - ESP8266 I/O Plug One**Note: Pin 1 is marked RST. All GPIOs are 3.3V and are not 5V compatible.**

NAME	PIN	I/O	DESCRIPTION
RST	J17/ 1	I/O	this is the reset pin for the ESP8266, pulled high by default. When pulled down to ground momentarily it will reset the ESP8266 system. This pin is 5V compliant. Connected to RESET Button
ADC	J17/ 2	A	Internal ADC in the ESP8266. Maximum 1.0V. Use the ADC inputs on the WeatherPlus built In ADS1015 instead.
CHPD	J17/ 3	I/O	This is the enable pin for the ESP8266, pulled high by default. When pulled down to ground momentarily it will reset the ESP8266 system. This pin is 3.3V logic only.
#16	J17/ 4	I/O	GPIO #16 can be used to wake up out of deep-sleep mode, you'll need to connect it to the RST pin
#14	J17/ 5	I/O	Connected to Anemometer Output. 10K Pullup to 3.3V
#12	J17/ 6	I/O	Connected to Rain Bucket Output. 10K Pullup to 3.3V
#13	J17/ 7	I/O	Lightning Detector Interrupt output. May be used as an 3.3V GPIO if the lightning detector is not added.
VIN	J17/ 8	A	Maximum 20V. Schottky Diode protected. The board will take the power from VIN or VBAT whichever is highest voltage.
VBAT	J17/ 9	A	Maximum 20V. Schottky Diode protected. The board will take the power from VIN or VBAT whichever is highest voltage.
GND	J17/ 10	A	Ground

JP18 - ESP8266 I/O Plug Two

Note: Pin 1 is marked TX. All GPIOs are 3.3V and are not 5V compatible.

NAME	PIN	I/O	DESCRIPTION
TX	J18/ 1	O	Serial Output - Connected to TX pin on JP16)
RX	J18/ 2	I	Serial Input (NOT 5V Compatible!)- Connected to RX pin on JP16
#5	J18/ 3	I/O	SDA 3.3V I2C (note reversed on chip. Must use wire(5,4) instead of wire(4,5) in the Arduino IDE. 10K Pullup to 3.3V
#4	J18/ 4	I/O	SCL 3.3V I2C output (note reversed on chip. Must use wire(5,4) instead of wire(4,5) in the Arduino IDE. 10K Pullup to 3.3V
#0	J18/ 5	I/O	Does not have an internal pullup, Is connected to both the GPIO0 Push Button and the red GPIO0 LED. This pin is used by the ESP8266 to determine when to boot into the bootloader. If the pin is held low during power- the ESP8266 will go into bootloading. You can use it as an output. 3.3V Compliant. Note: Writing 0 turns the LED on, writing 1 turns the LED off.
#2	J18/ 6	I/O	Pullup to 3.3V. Is connected to the blue LED near the WiFi antenna.. You can use it as an output. 3.3V Compliant. Note: Writing 0 turns the LED on, writing 1 turns the LED off.
#15	J18/ 7	I/O	Is additionally used to detect boot-mode. It has a pulldown resistor connected to it. Do not pull this high on startup. Can be used as an output
3V3	J18/ 8	A	3.3V regulator output
LD0	J18/ 9	A	This is the enable pin for the 3.3V regulator. By default its pulled high. When connected to ground it will turn off the 3.3V regulator and will cut power to the entire WeatherPlus Boar. There is a 10K pullup is to whatever is greater, VIN or VBAT
GND	J18/ 10	A	Ground

JP2 - WeatherOut

This is the WeatherPlus WeatherRack optional sensor outputs.

NAME	PIN	I/O	DESCRIPTION
WindVane	JP2 / 1	O	Connect to A/D Input on Arduino. N/C for Raspberry Pi. Use an external ADC for Raspberry Pi (such as the ADS1015 on the WeatherPlus board)
RainBucket	JP2 / 2	O	Active Low Interrupt on each click of the Rain Bucket - Not Debounced. 10K pullup resistor
Anemometer	JP2 / 3	O	Active Low Interrupt on each click of the Anemometer - Not Debounced. 10K pullup resistor
GND	JP2 / 4	A	Connected to GND

JP4 - I2C for Raspberry Pi

This is a 3.3V I2C bus for use by the Raspberry Pi. **Not a 5V I2C bus.** Use JP10 to connect 5V SCL and SDA from the Arduino.

NAME	PIN	I/O	DESCRIPTION
SCL	JP4 / 1	I	Serial bus clock line; open-drain input. 10K Pullup on board
SDA	JP4 / 2	I/O	Serial bus data line; open-drain input/output. 10K Pullup on board
3V3	JP4 / 3	A	Connected to 3V3 (3.3V I2C Bus)
GND	JP4 / 4	A	GND

JP10 - I2C for Arduino

This is a 5V I2C bus for use by the Arduino. **Not a 3.3V I2C bus.** Use JP4 to connect 3.3V SCL and SDA from the Raspberry Pi. Note that if you are using an Arduino, you **do not connect** the power pin on JP4 to 5V. Either connect the pin to 3.3V or leave it open.

NAME	PIN	I/O	DESCRIPTION
SCL	JP10 / 1	I	5V Tolerant Serial bus clock line; open-drain input. No Pullup on board
SDA	JP10 / 2	I/O	5V Tolerant Serial bus data line; open-drain input/output. No Pullup on board

Grove Connectors

The WeatherPlus has two identical Grove I2C connectors, I2C0 and I2C1. These are for plugging in Grove I2C devices, such as the Grove OLED Display and the Grove AM2315 Outside Temperature/Humidity Sensor. These are 3.3V I2C Grove Connectors. Note that you can plug neither device in either slot.

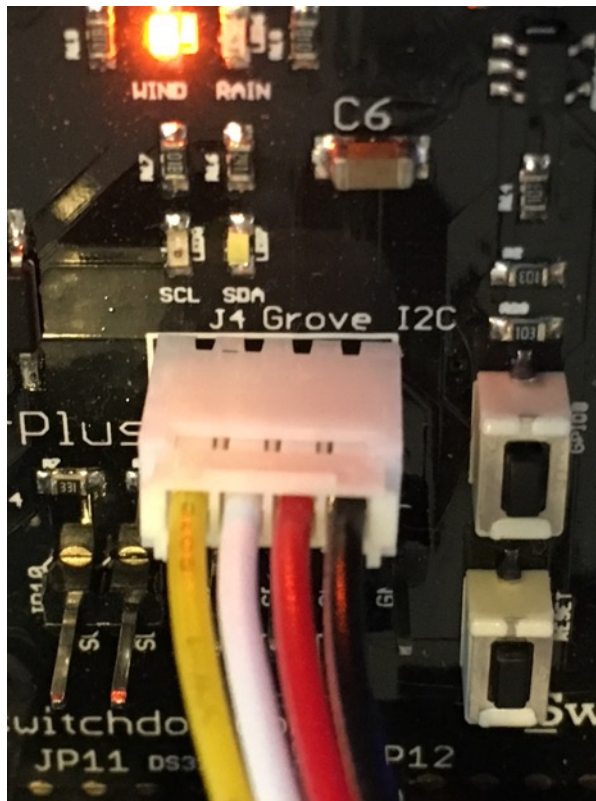

SwitchDoc Labs

WeatherPlus boards before 0011-021916-01 only have one Grove connector, easily fixed with an inexpensive 4 channel Grove Hub.

JP6 - Optional Non-Volatile FRAM

The MB85RC256V is a 256K-bits FRAM with serial interface (I2C), using the ferroelectric process and CMOS process technologies for forming the nonvolatile memory cells. A FRAM is able to write high-speed even though it is a nonvolatile memory. The optional FRAM module is much faster to read and write to than the included EEPROM device.

It is suitable for the log management and the storage of the resume data, etc. Project Curacao (www.switchdoc.com) uses it to record Weather data during the night when the Raspberry Pi is not powered up. Each byte can be read and written instantaneously (like SRAM) but will keep the memory for 95 years at room temperature. Each byte can be read/written 10,000,000,000 times.

NAME	PIN	I/O	DESCRIPTION
3V3	JP6 / 1	A	3.3V
GND	JP6 / 2	A	GND
WP	JP6 / 3	I	Write Protect pin. This is used to force write protection so you cannot write to the FRAM. It has an internal pulldown. Bring to a high voltage (VCC) to turn on WP
SCL	JP6 / 4	I/O	Serial bus clock line; open-drain input.
SDA	JP6 / 5	I/O	Serial bus data line; open-drain input/output.
A2	JP6 / 6	I	High selection bit (use A2,A1,A0 as three bits and add to 0x50)
A1	JP6 / 7	I	Middle selection bit (use A2,A1,A0 as three bits and add to 0x50)
A0	JP7 / 8	I	Low selection bit (use A2,A1,A0 as three bits and add to 0x50)

JP8 - A/D Inputs for ADS1015 ADC

Connect up external A/D Inputs using this header. The ADS1015 chips have a base 7-bit I2C address of 0x48 and an addressing scheme that allows four different addresses using just one address pin. To program the address, connect the address pin as follows:

- 0x48 (1001000) ADDR -> GND
- 0x49 (1001001) ADDR -> VDD
- 0x4A (1001010) ADDR -> SDA
- 0x4B (1001011) ADDR -> SCL

The ADDR is internally connected to VDD through a 10K Resistor, for address 0x49.

NAME	PIN	I/O	DESCRIPTION
ADDR	JP8 / 1	I	I2C slave address select
ALRT	JP8 / 2	O	Digital comparator output or conversion ready
A0	JP8 / 3	A	Differential channel 1: Positive Input or single-ended channel 1 input
A1	JP8 / 4	A	Differential channel 1: Negative Input or single-ended channel 2 input. Connected to WindVane Input on JP1
A2	JP8 / 5	A	Differential channel 2: Positive Input or single-ended channel 3 input.
A3	JP8 / 6	A	Differential channel 2: Negative Input or single-ended channel 4 input

JP10 - I2C for Arduino

This is a 5V I2C bus for use by the Arduino. **Not a 3.3 I2C bus.** Use JP4 to connect 3.3V SCL and SDA from the Raspberry Pi or use the Grove connectors

NAME	PIN	I/O	DESCRIPTION
SCL	JP10 / 1	I	5V Tolerant Serial bus clock line; open-drain input. 10K Pullup on board
SDA	JP10 / 2	I/O	5V Tolerant Serial bus data line; open-drain input/output. 10K Pullup on board

SwitchDoc Labs

JP11 - Included DS3231/EEPROM Real Time Clock and Storage

The DS3231 is a low-cost, extremely accurate I²C real-time clock (RTC) with an integrated temperature-compensated crystal oscillator (TCXO) and crystal. The device incorporates a battery input, and maintains accurate timekeeping when main power to the device is interrupted. This is included with the WeatherPlus Board.

NAME	PIN	I/O	DESCRIPTION
32K	JP11 / 1	O	32kHz Output. This open-drain pin requires an external pullup resistor to 3V3. When enabled, the output operates on either power supply. It may be left open if not used.
SQW	JP11 / 2	O	Active-Low Interrupt or Square-Wave Output. This open-drain pin requires an external pullup resistor to 3V3. It may be left open if not used.
SCL	JP11 / 3	I/O	Serial bus clock line; open-drain input. No Pullup on WeatherPlus board.
SDA	JP12 / 4	I/O	Serial bus data line; open-drain input/output. No Pullup on WeatherPlus board
3V3	JP12 / 5	A	Connected to 3V3 (3.3V)
GND	JP12 / 5	A	GND

JP12 - Optional Lightning Detector - MOD-1016

The MOD-1016 (Embedded Adventures) is an AS3935 based lightning and storm sensor. It comes pre-calibrated, meaning that you don't have to write complex frequency calculation code, you can simply program the correct calibration details and get cracking finding storms. The AS3935 is a programmable fully integrated Lightning Sensor IC that detects the presence and approach of potentially hazardous lightning activity in the vicinity and provides an estimation on the distance to the head of the storm. The embedded lightning algorithm checks the incoming signal pattern to reject the potential man-made disturbers.

The AS3935 can also provide information on the noise level and inform the external unit (e.g. microcontroller) in case of high noise conditions, with the noise floor generator and noise floor evaluation blocks.

NAME	PIN	I/O	DESCRIPTION
3V3	JP12 / 1	A	Connected to 3V3 (3.3V)
CS	JP12 / 2	I	N/C
IRQ	JP12 / 3	O	Interrupt request from the AS3935
SCL	JP12 / 4	I	Serial bus clock line; open-drain input. No Pullup on WeatherPlus board.

SwitchDoc Labs

MISO	JP12 / 5	I	N/C
SDA	JP12 / 6	I/O	Serial bus data line; open-drain input/output. No Pullup on WeatherPlus board
GND	JP12 / 7	A	GND

Software

The Arduino software for WeatherPlus is available on github.com/switchdoclabs/OurWeatherWeatherPlus

The Raspberry Pi server software for WeatherPlus is available on github.com/switchdoclabs/OurWeatherRaspberryPi