



The **USB PowerControl** board is a USB to USB solid state relay. It comes in two flavors, one with an Active High Enable line and the other with an Active Low Enable line.

The software for this device is simple. You use GPIO lines to turn it on or off (*or connect it directly to your LiPo battery for automatic control!*). It controls the 5V line that powers a USB device plugged into the female USB A power end of the board.

Features and Benefits:

- Can Switch the Power to any device plugged into the Female A USB port On/Off
- Controlled by a single battery control line or a GPIO Port
- Enable and Control Lines on Grove Connector
- Implements Hysteresis on battery Control line
- 3.8V/3.3V Turn On/Off Voltage on Battery Control Line
- 3.3V Turn Off Voltage on Battery Control Line
- Unit can be controlled by GPIO or by Battery Level
- Over Current Protection
- Thermal Shutdown
- Reverse Current Blocking
- Can be connected to GPIO Pin or directly to LiPo Battery
- Supports both Arduino and Raspberry Pi
- Has Dual USB ports - no more cutting USB cables
- Designed to work with SunAir and SunAirPlus Solar Power Controllers
- Low Cost
- Quantity Discounts Available
- Immediate Availability

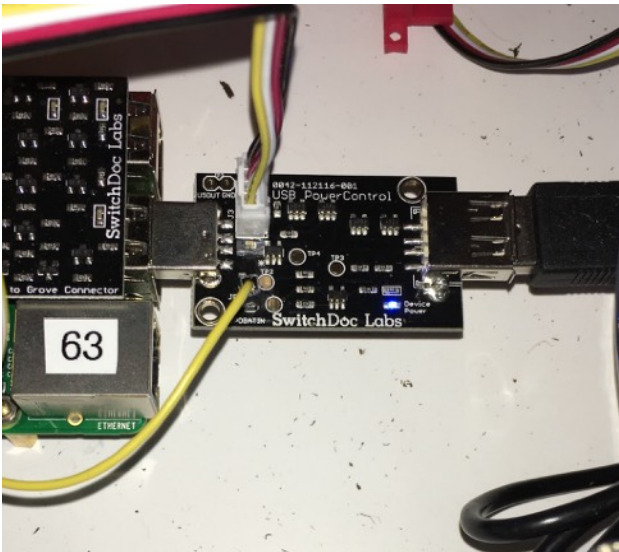

Introduction

The USB PowerControl and the USB PowerControlNE Boards are digitally controlled power switches for your Arduino or Raspberry Pi. Anything you can plug into a USB port can be controlled with USB PowerControl. It's easy to hook up. You connect a control line (a GPIO line or the output of a LiPo battery) to the LIPOBATIN line and if the line is LOW (< ~3.3V) the USB Port is off. If it is HIGH (above 3.8V) the USB Port is turned on and you have 5V of power to the USB plug.

This board was initially designed to sit in-between a Solar Power Controller (such as [SunAir/SunAirPlus](#)) and a

Raspberry Pi / Arduino. The input to the board was designed to come directly from a LiPo battery so the computer won't be turned on until the LiPo battery was charged up above 3.8V. We provide a hysteresis circuit so the board won't turn off until the voltage goes below around 3.3V. This is an excellent board to shut on and off USB powered devices like a Raspberry Pi and Arduino. It works just like a conventional relay, except that it requires virtually no current to keep it on or off. Like a latching relay.

We have now added a Grove Digital Input that allows you to control the USB PowerControl using two GPIO Lines (one enable and one control line) to switch on and off from a Grove Digital Port. The Grove Enable Line, when high, disables the LIPOBATIN line and makes control of the device under the Grove Control Line. When the Grove Enable Line is low, the LIPOBATIN line controls the relay as in the original USB PowerControl. The Grove Enable Line is pulled down by a 43K resistor so if it is disconnected, the USB PowerControl is compatible with the original USB PowerControl.

The difference between the normal (0042) and the NE (0043) version of this board is the sense of the ENABLE Line. It is active high for the 0042 board and active low for the NE (0043) board.

Check out our tutorial on the Grove Connector System on www.switchdoc.com

Block Diagram

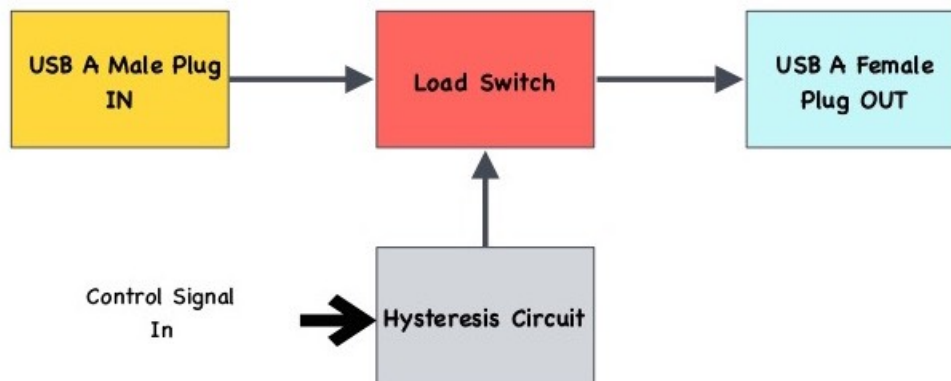

How To Use

To use the USB PowerControl device, plug a female USB A cable from the power source for the USB (in the case of SunAir and SunAirPlus, you can plug it directly into the output USB connector on the board). Then

you plug in the Raspberry Pi or Arduino into the USB A Female Out plug. The USB PowerControl is controlled by the voltage on the input pin LIPOBATIN.

If you wish to control the USB PowerControl by the use of a Grove Digital connector, D0 on the Grove connector is the Grove Control Line and the D1 on the Grove connector is the Grove Enable Line. Note that these inputs can be connected to Jumper Wires and are both 3.3V and 5V compatible.

Theory of Operation

Load Switch

The USB PowerControl Board uses a Fairchild FPF2123 Full Function Load Switch as the main power switch.

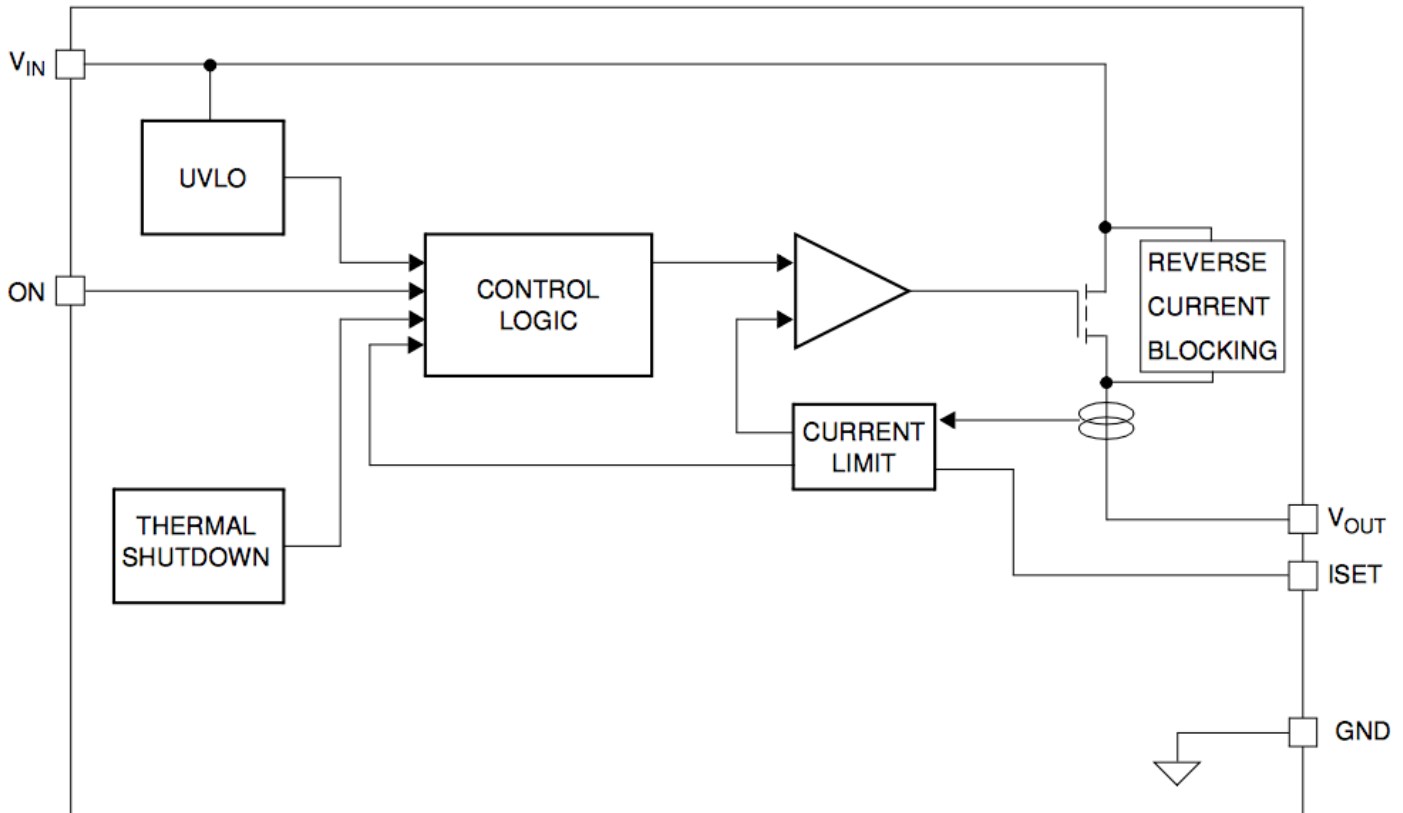

The FPF2123 provides full protection to systems and loads which may encounter large current conditions. These devices contain a 0.125 current-limited P-channel MOSFET which can operate over an input voltage range of 1.8-5.5V. The device is set for a minimum shutdown current of 1010mA with a maximum current shutdown of 1860mA. Internally, current is prevented from flowing when the MOSFET is off and the output voltage is higher than the input voltage. Switch control is by a logic input (ON) capable of interfacing directly with low voltage control signals. The FPF2123 contains thermal shutdown protection which shuts off the switch to prevent damage to the part when a continuous over-current condition causes excessive heating. When the switch current reaches the current limit, the parts operate in a constant-current mode to prohibit excessive currents from causing damage. If the constant current condition still persists after 10ms, these parts will shut off the switch. The FPF2123 has an auto-restart feature which will turn the switch on again after 160ms if the ON pin is still active.

Hysteresis Control Circuit

The USB PowerControl Hysteresis circuit on LIPOBATIN is based on a TA75S39 Operational Amplifier used as a comparator. A comparator with hysteresis has two important thresholds: upper and lower. Unlike a simple comparator, however, the output of the comparator doesn't depend solely on whether the input is above or below one of these thresholds. It depends on both the current state of the output **and** the current value of the input. If the output is high, it will stay high until the input voltage drops below the lower threshold. If the output is low, it will stay low until the input voltage rises above the upper threshold.

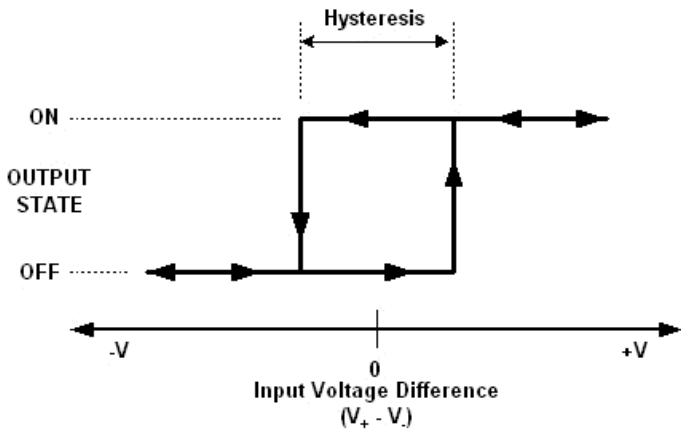

The diagram to the right shows a hysteresis 'loop' that describes how a comparator functions. The horizontal 'X' axis is the input, and represents the difference of the two input voltages. The vertical "Y" axis represents the comparator's output state.

If the comparator is initially 'OFF', the MINUS input voltage has to become slightly above the PLUS input voltage before the comparator output turns 'ON'. This is represented by moving right along the bottom part of the loop.

Once the comparator is 'ON', the MINUS input voltage needs to drop slightly below the PLUS input voltage before it turns 'OFF' again (moving left along the top of

the loop).

The 'ON' state is set in the USB PowerControl to be 3.8V and the 'OFF' state is set to be about 3.3V. The output of the comparator drives the input to the Load Switch.

 Grove GPIO Control Circuitry
For USB PowerControl (0042-USBPC-DSBT)

This circuitry is provided to allow the USB PowerControl to be controlled by either LIPOBATIN or the state of the CONTROL Line (J3 Pin 1). ENABLE (J3 Pin 2) controls whether the USB PowerControl is switched by LIPOBATIN or the CONTROL line.

The truth table for the USB PowerControl s given below:

USB PowerControl (0042-USBPC-DSBT)			
LIPOBATIN	ENABLE	CONTROL	USB OUT POWER
0	0	0	OFF
0	0	1	OFF
0	1	0	OFF
0	1	1	ON
1	0	0	ON
1	0	1	ON
1	1	0	OFF
1	1	1	ON

For USB PowerControlNE (0043-USBPCNE-DSBT)

This circuitry is provided to allow the USB PowerControl to be controlled by either LIPOBATIN or the state of the CONTROL Line (J3 Pin 1). ENABLE (J3 Pin 2) controls whether the USB PowerControl is switched by LIPOBATIN or the CONTROL line.

The truth table for USB PowerControlNE is given below:

USB PowerControlNE (0043-USBPCNE-DSBT)			
LIPOBATIN	ENABLE	CONTROL	USB OUT POWER
0	1	0	OFF
0	1	1	OFF
0	0	0	OFF
0	0	1	ON
1	1	0	ON
1	1	1	ON
1	0	0	OFF
1	0	1	ON

Operating Values

		Min	Normal	Max	Unit
Vin	Input USB 5V Line		5.0	5.25	V
I _{max}	Maximum Current before Shutdown	1010	1350	1690	mA
R _{on}	On Resistance		125	200	mOhms
LIPOBATINVon	Control Input ON Voltage		3.8	3.9	V
LIPOBATINVon	Control Input OFF Voltage	3.2	3.3		V
T _{on}	Turn On Time		25		uS
T _{off}	Turn Off Time		70		uS
T _{or}	Operating Temperature Range	-40		125	degrees C

Pin Locations

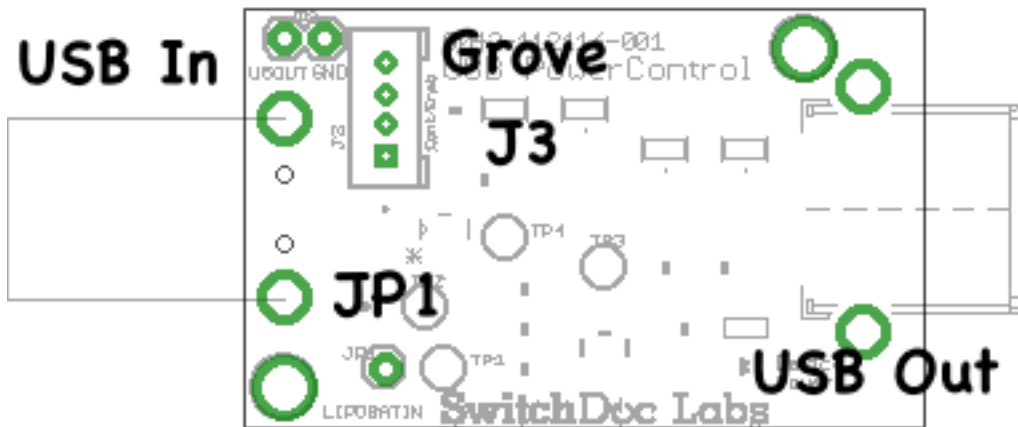

Physical dimensions of board: 65 mm x 26mm x 12mm(max).

I/O Key:

I - Digital Input
O - Digital Output
A - Analog

Pin Functions

JP1 - LIPOBATIN

Input Control Line for USB PowerControl

NAME	PIN	I/O	DESCRIPTION
LIPOBATIN	JP1 / 1	I	Control Input for USB PowerControl. Connected to Hysteresis Comparator circuitry. See Operation Conditions for Von/Voff

JP2 - Power Utility Pins

Used for additional connections to 5V USB Output voltage and Ground.

NAME	PIN	I/O	DESCRIPTION
5VUSBOUT	JP2 / 1	A	5V USB Out voltage. Controlled by LIPOBATIN or Grove GPIO
GND	JP2 / 2	A	Ground

J3 - Grove GPIO Control Plug

Used for additional connections to 5V USB Output voltage and Ground.

NAME	PIN	I/O	DESCRIPTION
CONTROL	J3 / 1	D	USB PowerControl ON = 1, OFF = 0 - Enabled by ENABLE - pulled down to GND with 43K Ohm resistor
ENABLE	J3 / 2	D	Enable = 0, LIPOBATIN Controls. Enable = 1, CONTROL controls, - pulled down to GND with 43K Ohm resistor The NE version has Enable = 1 LIPOBATIN controls. Enable = 0, CONTROL controls - NE version Enable is pulled to VDD with 43K Ohm resistor.
VDD	J3 / 3	A	N/C - No Connection
GND	J3 / 4	A	Ground

Application Diagram

