



The **Thunder Board** is an Arduino and Raspberry Pi Grove compatible breakout board with a full set of connectors. No external antennas required! It is designed for use in Low Power applications such as battery and Solar Power applications. It can detect lightning up to 40km away.

Features and Benefits:

- 2.4V - 5.5V operation
- I2C Interface - 0x01-0x03 Address
- Buffered I2C Interface
- Grove Connectors - No Soldering Required
- Lightning sensor warns of lightning storm activity within a radius of 40km
- Distance estimation to the head of the storm down to 1km in 14 steps
- Detects both cloud-to-ground and intra-cloud (cloud-to-cloud) flashes
- Embedded man-made disturber rejection algorithm
- Programmable detection levels enable threshold setting for optimal controls
- I2C interface is used for control and register reading
- Antenna Tuning to compensate variations of the external components
- Power-down, listening, and active mode
- Full Test Code Supplied
- Quantity Discounts Available
- Immediate Availability

Introduction

The Austrian Microsystems AS3935 is a programmable Lightning Sensor IC that detects the presence and approach of potentially hazardous lightning activity in the vicinity and provides an estimation on the distance to the head of the storm. The embedded lightning algorithm checks the incoming signal pattern to reject the potential man-made disturbers and various noise sources.

The AS3935 can also provide information on the noise level and inform the Raspberry Pi or Arduino of high noise conditions. It comes pre-calibrated, meaning that you don't have to write complex frequency calculation code, you can simply program the correct calibration details and get cracking finding storms.

Theory of Operation

AM3935 Lightning Detector

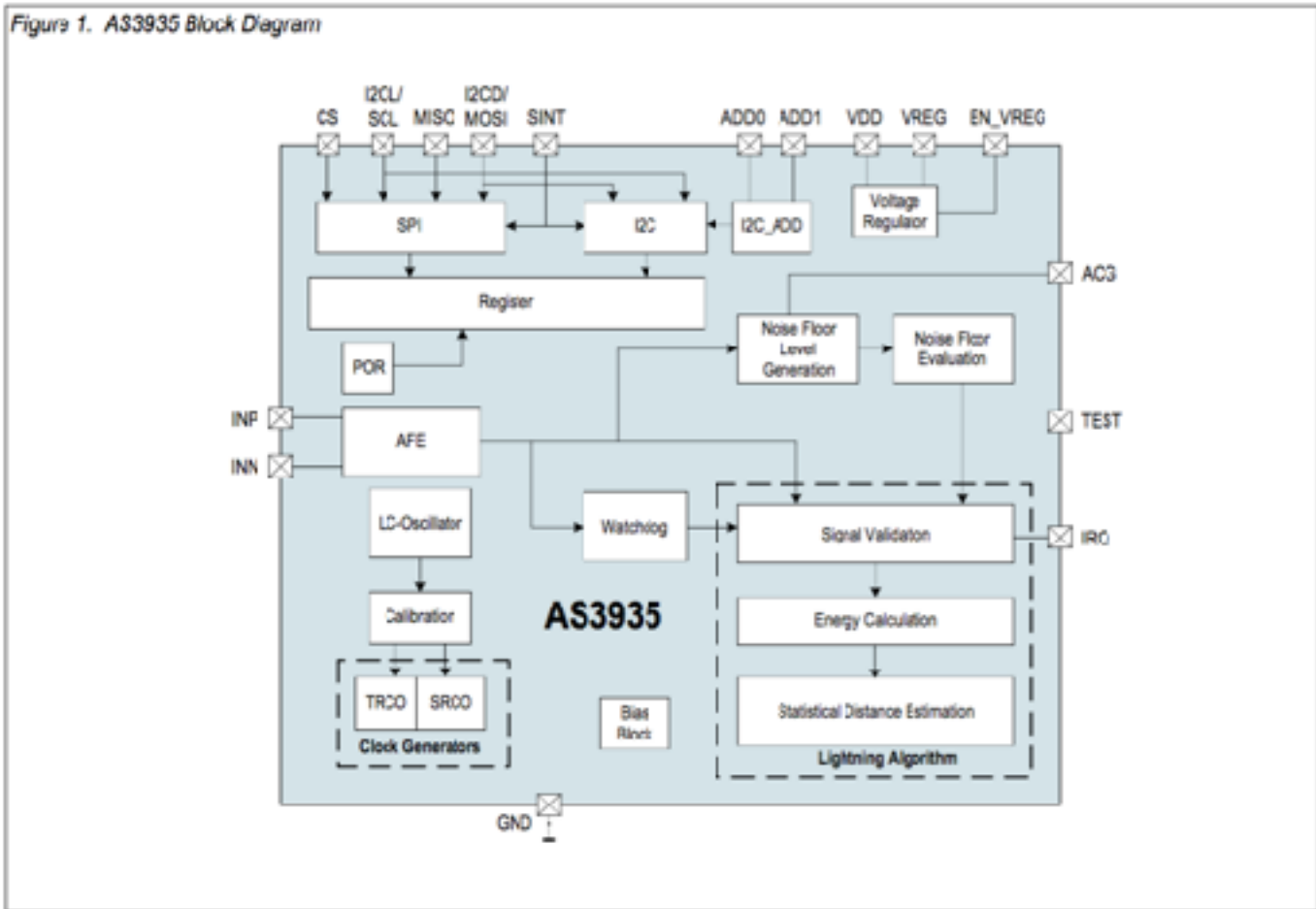

The AS3935 can detect the presence of an approaching storm with lightning activities and provide an estimation of the distance to the leading edge of the storm, where the leading edge of the storm is defined as the minimum distance from the sensor to the closest edge of the storm. The embedded hardwired distance estimation algorithm of the AS3935 issues an interrupt on the IRQ pin every time a lightning is detected. The estimated distance which is displayed in the distance estimation register does not represent the distance to the single lightning but the estimated distance to the leading edge of the storm.

The system integration consists mainly of the AS3935 and an external control unit (e.g. MCU) for the IC initialization and interrupt management (IRQ).

The internal voltage regulator can be enabled by connecting EN_VREG to VDD. If the internal regulator is not used, capacitor C3 is not needed and VREG must be connected to VDD. In this case, the AS3935 can be directly supplied by VREG and VDD (EN_VREG to GND). The Thunder Board uses the internal regulator.

The Block diagram of the AS3935 is shown above. The external antenna is directly connected to the Analog Front-end (AFE), which amplifies and demodulates the received signal. The watchdog continuously monitors the output of the AFE and alerts the integrated lightning algorithm block in the event of an incoming signal. The lightning algorithm block validates the signal by checking the incoming signal pattern, calculates the energy and then the AS3935 provides the MCU with an estimate of the distance to the head of the storm. The lightning algorithm block, processing the demodulated signal, can distinguish between lightning signal and man-made disturbers. If the received signal is classified as a man-made disturber, then the event is rejected and the system automatically goes back into listening mode to minimize current consumption. If the incoming signal identifies a lightning event, then the statistical distance estimation block performs an estimation of the distance to the head of the storm.

The LC oscillator together with the calibration block can calibrate both the TRCO and the SRCO clock generator to compensate process variations.

The full AS3935 specification is available here:

<http://ams.com/eng/Products/Wireless-Connectivity/Wireless-Sensor-Connectivity/AS3935>

Pull up resistors

The Thunder Board comes with no pull up resistors

Warning

The Thunder Board contains world-class, award winning, super advanced technology from AMS. However, this device should NOT be used as the basis for evacuation or safety decisions in the case of storms, hurricanes, cyclones or other weather events.

Please rely on local authorities to tell you what to do.

However, if your Thunder Board gave you prior warning of a storm before local authorities did, and subsequently enabled you to save your cat from being swept away or your washing from getting wet, we'd like to hear about it!

Operating Values

	Min	Normal	Max	Unit
VDD	2.4		5.25	V
I _{dd} *		8uA while in power down mode and 65uA when listening for lightning. When verifying lightning and calculating distances, the device consumes 350uA.		uA

Grove Lightning Detector Board Jumper Pin, LED and Plug Locations

Physical dimensions of board: 40mm x 28mm x 10.0mm(max). Two mounting holes.

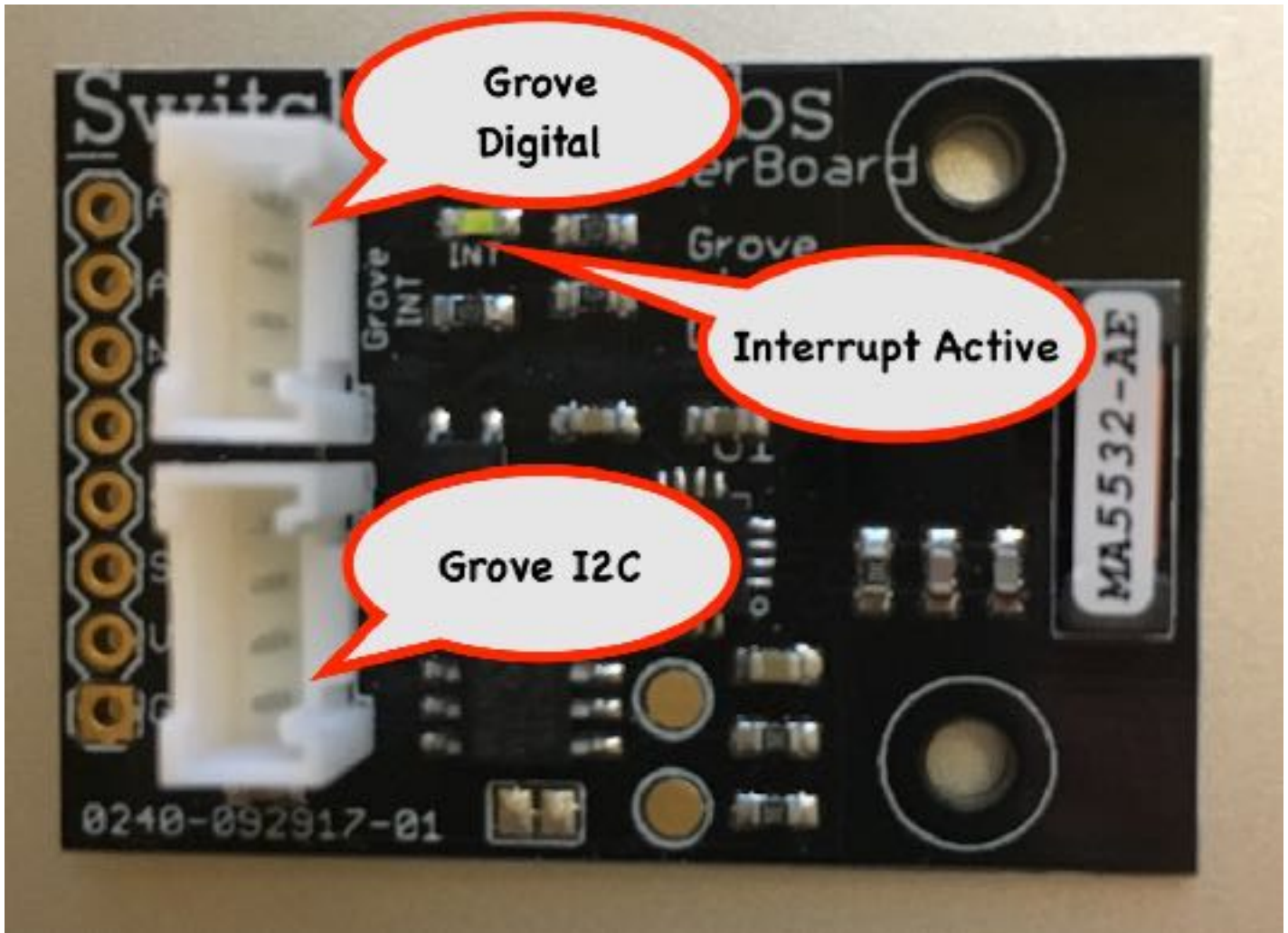

What is a Grove Connector?

The way we have been wiring I2C connections before just didn't work for large projects. Basically, we used to put the I2C bus to screw

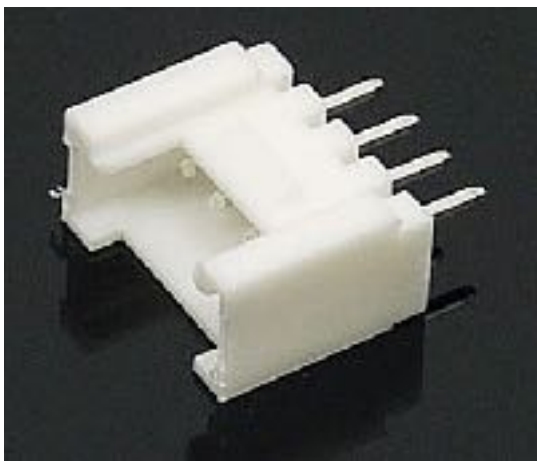

terminals or snap down connectors and then ran wires to each device. This would not work for complex projects. Because of this, we moved to Grove connectors.

There are dozens of Grove I2C sensors out now. Many different kinds of cables and I2C Hubs.

We quickly found the connectors and their respective cables very useful. With the large selection of Grove I2C devices available, we decided to include a Grove connector on all our future I2C boards. The white connectors on the Grove Lightning Detector board picture at the top are Grove connectors for easy, non-soldered connections to the I2C bus and for data inputs. The picture below shows the SunRover robot built using Grove connectors for the 8 different I2C busses in the robot. A Grove OLED display is shown underneath the picture.



Connecting to Grove Connectors

There are a number of Grove shields and Hats for Raspberry Pi and Arduino devices.

Grove I2C Connectors are keyed so they can not be plugged in incorrectly. Below is the I2CMux board hooked up with both Grove and non-Grove devices.

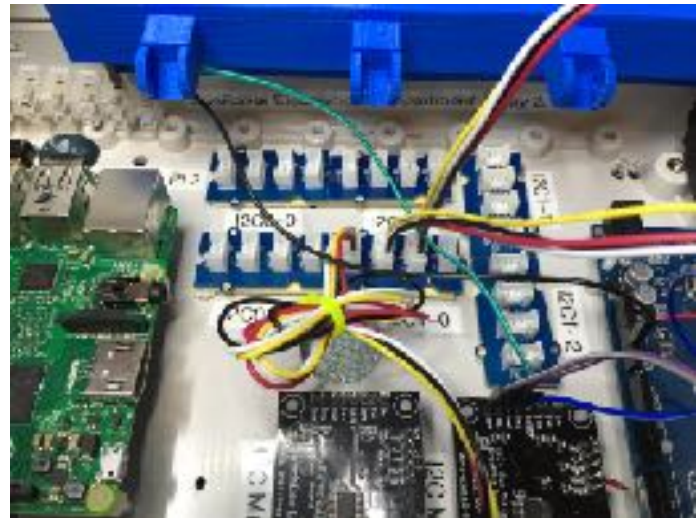

What Grove Connectors Are On The Grove Lightning Detector?





There are two types of Grove Connectors on the Grove Lightning Detector board, a Grove I2C connector and a Grove Digital connector for the Interrupt line to the microcontroller.

Grove Digital

A digital Grove connector consists of the standard four lines coming into the Grove plug. The two signal lines are generically called D0 and D1. Most modules only use D0, but some do (like the LED Bar Grove display) use both. Often base units will have the first connector called D0 and the second called D1 and they will be wired D0/D1 and then D1/D2, etc.

Grove Digital		
Pin 1	D0	Primary Digital Input/Output
Pin 2	D1	Secondary Digital Input/Output
Pin 3	VDD	Power for Grove Module (5V or 3.3V)
Pin 4	GND	Ground

Grove Analog

An Grove Analog connector consists of the standard four lines coming into the Grove plug. The two signal lines are generically called A0 and D0. Most modules only use A0. Often base units will have the first connector called A0 and the second called A1 and they will be wired A0/A1 and then A1/A2, etc.

Grove Analog		
Pin 1	A0	Primary Analog Input
Pin 2	A1	Secondary Analog Input
Pin 3	VDD	Power for Grove Module (5V or 3.3V)
Pin 4	GND	Ground

Grove I2C

SwitchDoc Labs customers know that our favorite devices are I2C sensors. There are many types of I2C Grove sensors available. Most are 5V/3.3V devices, but there are a few that are only 3.3V or 5.0V. You need to check the specifications.

The Grove I2C connector has the standard layout. Pin 1 is the SCL signal and Pin 2 is the SDA signal. Power and Ground are the same as the other connectors. This is another special version of the Grove Digital Connector. In fact, often the I2C bus on a controller (like the ESP8266, Raspberry Pi and the Arduino) just uses Digital I/O pins to implement the I2C bus. The pins on the Raspberry Pi and Arduino are special with hardware support for the I2C bus. The ESP8266 is purely software.

Note that the Grove I2C Connectors on the Grove Lightning Detector is a 5V or 3.3V (depending on what VDD is connected to) I2C connector.

Grove I2C		
Pin 1	SCL	I2C Clock
Pin 2	SDA	I2C Data
Pin 3	VDD	Power for Grove Module (5V or 3.3V)
Pin 4	GND	Ground

I/O Key:

- I - Digital Input
- O - Digital Output
- A - Analog

Grove Connections

J1 - Grove I2C

This Connector can be used to connect up to a processor such as the Raspberry PI or to an I2C Hub expander. See articles and application notes on www.switchdoc.com.

J1 - Grove I2C		
Pin 1	SCL	I2C Clock
Pin 2	SDA	I2C Data
Pin 3	VDD	Power for Grove Module
Pin 4	GND	Ground

J2 - Grove Digital

J1 - Grove Digital		
Pin 1	IRQ	Active High IRQ from AS3935
Pin 2	N/C	No Connect
Pin 3	N/C	No Connect
Pin 4	GND	Ground

Jumper Pin Functions

JP1 - Pin Header Grove Lightning Detector Board

NAME	PIN	I/O	DESCRIPTION
AD1	JP1 / 1	I	High Bit Programmable I2C Interface
AD0	JP1 / 2	A	Low Bit Programmable I2C Interface
N/C	JP1 / 3		N/C
INT	JP1 / 4	O	Interrupt request from the AS3935
SCL	JP1 / 5	I/O	I2C Serial bus clock line; open-drain input. No Pullup on Thunder Board.
SDA	JP1 / 6	I/O	I2C Serial bus data line; open-drain input/output. No Pullup on Thunder Board.
VDD	JP1 / 7	A	VDD Power
GND	JP1 / 8	A	GND

Tips and tricks

I2C Considerations

The I2C Bus Address on the version 0240-092917-01 Thunder Board is fixed at 0x02. The Version number is in the lower left hand corner of the Thunder Board.

The I2C Bus Address on the version 0240-110317-01 Thunder Board defaults to 0x03. It is programmable to 0x01, 0x02 and 0x03. The Version number is in the lower left hand corner of the Thunder Board.

I2C Address	AD1	AD0	Notes
0x00	0	0	Don't use. Most MicroControllers don't handle 0x00
0x01	0	1	
0x10	1	0	Fixed I2C Address for version 0240-092917-01
0x11	1	1	Default for version 0240-110317-01 and later

Starting the Thunder Board

These are the steps you need to take to start using the Thunder Board. Your Thunder Board comes with software to calibrate your device— meaning you don't need to worry about measuring frequencies and checking results.

The factory calibrating tuning cap value will be fine for general use. When you have a Thunder Board in an enclosure or close to other electronics it is worth calibrating the tuning cap again.

AFE

There are many parameters to set and play with, but most importantly make sure you set the AFE gain to indicate if you are using the sensor inside or outside.

IRQ Response

The module will then pull IRQ high when something interesting has happened. Respond to this by waiting 2ms, then checking Register 0x03, bits 3-0. This will indicate:

- Noise detected, above the general background level. You can usually make this happen by putting the Thunder Board near a laptop or mobile phone, and the minimum acceptable of noise can also be configured.
- Disturber detected. A pulse was detected that was classified as man-made.
- Lightning. The real deal! At this point, you can query the Thunder Board to find out how far away the storm front is, and also a number that represents the amount of energy the lightning has.
- Due to the timing algorithms, the Thunder Board has decided that the storm is now a different distance away than previously reported.

In general, it cannot be stressed enough that while the Thunder Board will certainly let you know about electromagnetic pulses and its best guess about lightning distance, in real life storms do not generally hang around all the time ready for testing this module. Also, rain clouds don't necessarily mean lightning! Be patient, use your microcontroller to record what happens over time and enjoy learning more about storm patterns in your geographical location.

The easiest way to test your Thunder Board and project is to purchase the Thunder Board Lightning Simulator from SwitchDoc Labs. You can simulate far, mid and close lightning strikes.

NOTE: KEEPING YOUR THUNDER BOARD NEAR MONITORS, MOBILE PHONES OR OTHER EMF SOURCES WILL GENERATE NOISE AND DISTURBER INTERRUPTS AND CAN MASK ACTUAL LIGHTNING AND PULSES FROM THE THUNDER BOARD LIGHTNING SIMULATOR!

Software

You can find the software for the Thunder Board on [GitHub.com/switchdoclabs](https://github.com/switchdoclabs) for the Raspberry Pi and the Arduino