

The **Quad Power Management (QPM)** board is an easy to use 4 channel solid state relay board controlled by I2C. Each channel can switch up to 20V and 2.33A

Features and Benefits:

- Great for Robotics Projects
- I2C controlled
- 4 Independent Solid State Relays each with status LED
- Each is able to switch 20V and 2.3A
- 4 Additional GPIOs
- 4 interrupts available
- Software Drivers for Arduino and Raspberry Pi Included!
- Low Cost
- Quantity Discounts Available
- Immediate Availability

See the **QPMB applications section** at the end of this specification for examples of use.

Introduction

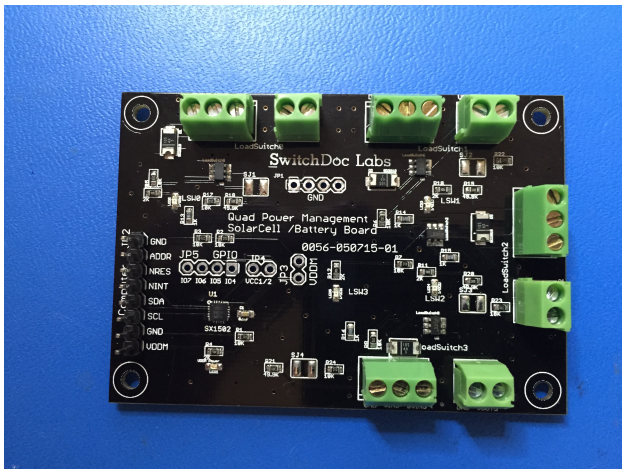

The Quad Power Management Board (QPM) is an easy to use 4 channel solid state relay board with an I2C interface.

SwitchDoc Labs has developed a Quad Power Management Board incorporating I2C controlled 4 Independent Solid State Relays each with LEDs to show what is going on with the board. **Each solid state relay is able to switch 20V and 2.3A.** You can switch DC signals and analog signals (with proper conditioning - you need to add a DC Offset for analog signals).

How To Use

Quad Power Management Board

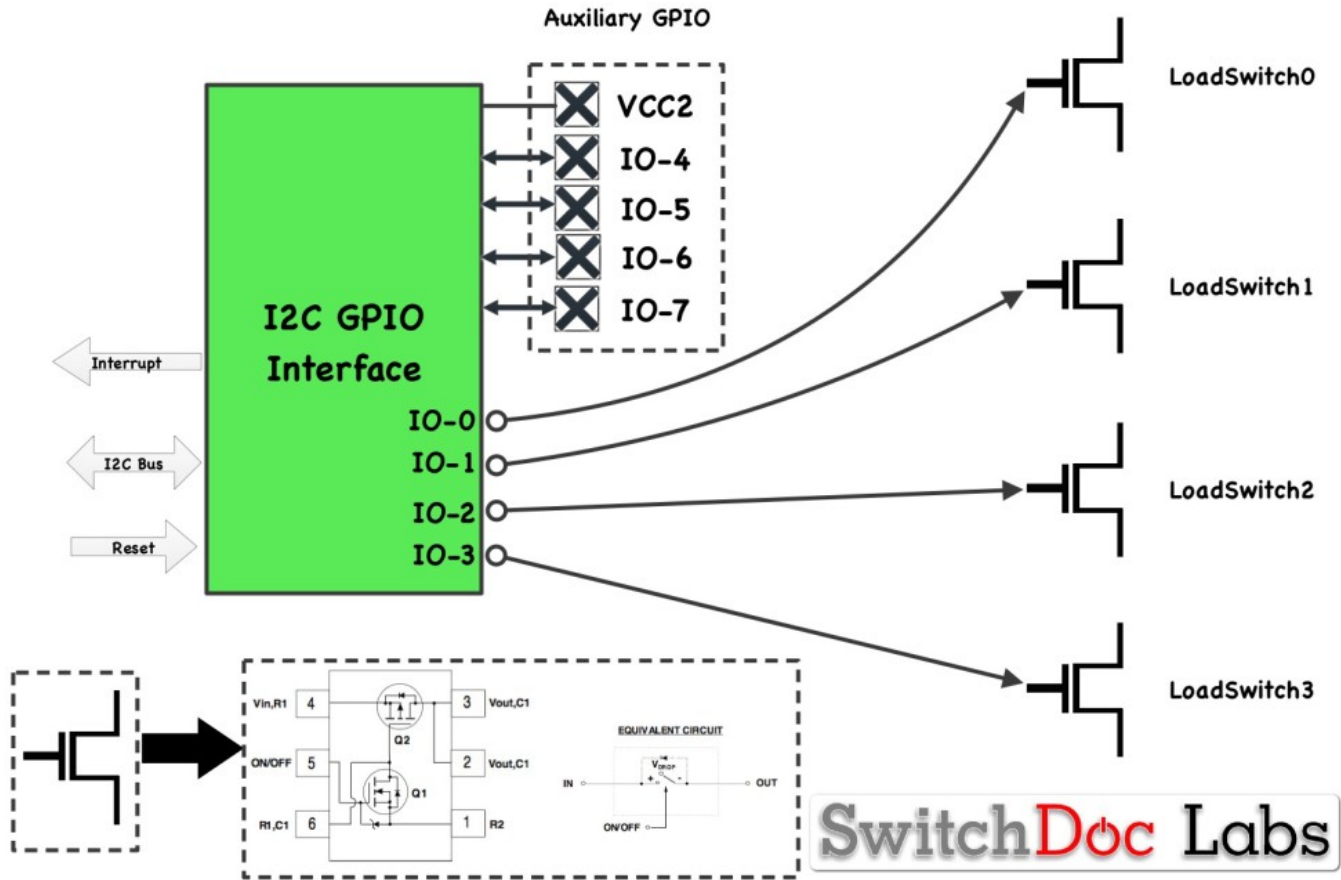

The QPM board is a four-channel, solid state relay (load switch) controlled by an I2C bus. The QPM board uses a SX1502 8 channel GPIO extender to control the four switches and provides 4 additional GPIOs. To use the QPM board, you connect up the I2C bus to an Arduino or Raspberry Pi and then connect the loads you want to switch to each of the four load switches. Typically, you connect the your load to the output (low) side of the switch (think of the current flowing though the switch - it goes from high voltage to lower voltage) and the input to the source of the current.

For example, to switch the power off on a device, you might hook up 5V to the input of a load switch and the load (the device) to the output.

The board also has two inputs for each switch. One protected by a diode (current can't flow OUT of the input because of the diode) and one unprotected by a diode. Your circuit application will determine which input you wish to use.

NOTE: Be careful when you hook up your loads and voltages to be switched by the QPM boards. You can blow out your supply and/or QPM board. Check and double check your wiring before you turn on the power. The QPM switches are limited to a maximum of 20V and 2.3A.

Quad Power Management Board Pinout

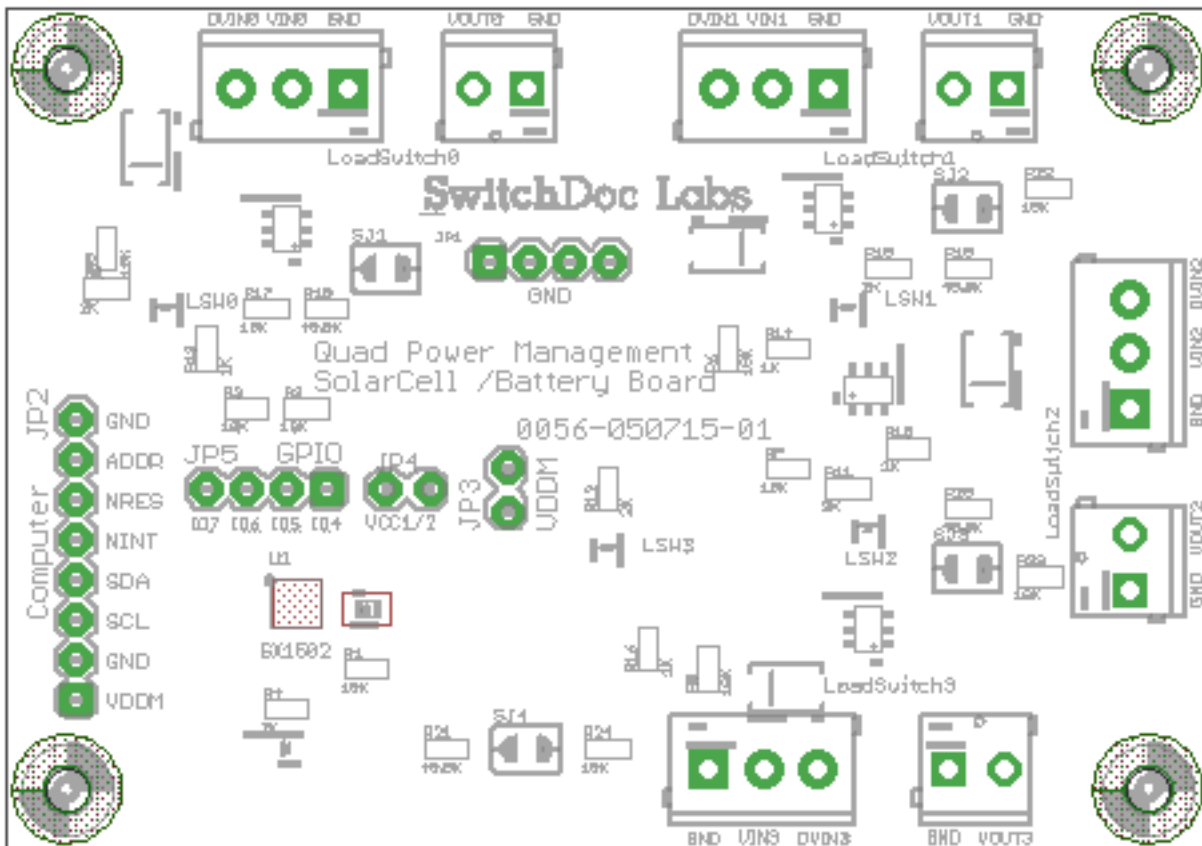

Wiring Lists

Raspberry Pi (A/B/A+/B+/Pi 2)

Signal Name	Raspberry Pi A/B/A+/B+/Pi 2	Quad Power Management Board
Power	3.3V (GPIO/1)	VDDM (JP2/1)
GND	GND (GPIO/6)	GND (JP2/2)
SCL	I2C1_SCL (GPIO/5)	SCL (JP2/3)
SDA	I2C1_SDA (GPIO/3)	SDA (JP2/4)

Signal Name	Quad Power Management Board	Quad Power Management Board
VDD1	VDDM (JP3/1)	VDD1 (JP4/1)
VDD2	VDDM (JP3/2)	VDD1 (JP4/2)

Arduino Uno

Signal Name	Arduino Uno	Quad Power Management Board
Power	5.0V (POWER/5V)	VDDM (JP2/1)
GND	GND (POWER/GND)	GND (JP2/2)
SCL	ADC5/SCL (ANALOG IN/A5)	SCL (JP2/3)
SDA	ADC4/SDA (ANALOG IN/A4)	SDA (JP2/4)

Signal Name	Quad Power Management Board	Quad Power Management Board
VDD1	VDDM (JP3/1)	VDD1 (JP4/1)
VDD2	VDDM (JP3/2)	VDD1 (JP4/2)

Arduinio Mega 2560

Signal Name	Arduino Mega 2560	Quad Power Management Board
Power	5.0V (POWER/5V)	VDDM (JP2/1)
GND	GND (POWER/GND)	GND (JP2/2)
SCL	SCL (COMMUNICATIONS 21)	SCL (JP2/3)
SDA	SDA (COMMUNICATIONS 20)	SDA (JP2/4)

Signal Name	Quad Power Management Board	Quad Power Management Board
VDD1	VDDM (JP3/1)	VDD1 (JP4/1)
VDD2	VDDM (JP3/2)	VDD1 (JP4/2)

Note: As with most SwitchDoc Labs Breakout Boards, the Quad Power Management Board does not contain any Pullup resistors for the I2C Bus SCL/SDA. You must supply those somewhere on your bus (10K resistors generally work well). We do not put pull-ups on boards because if you put multiple devices on the same I2C bus you will end up having too many pull-ups.

Theory of Operation

SX1502 IC

For more complete information, see the full SX1502 Specification at: <http://www.semtech.com/images/datasheet/sx150x.pdf>.

The QPM board uses a Semtech SX1502 8 GPIO I2C IC to control the four solid state relays on the QPM board.

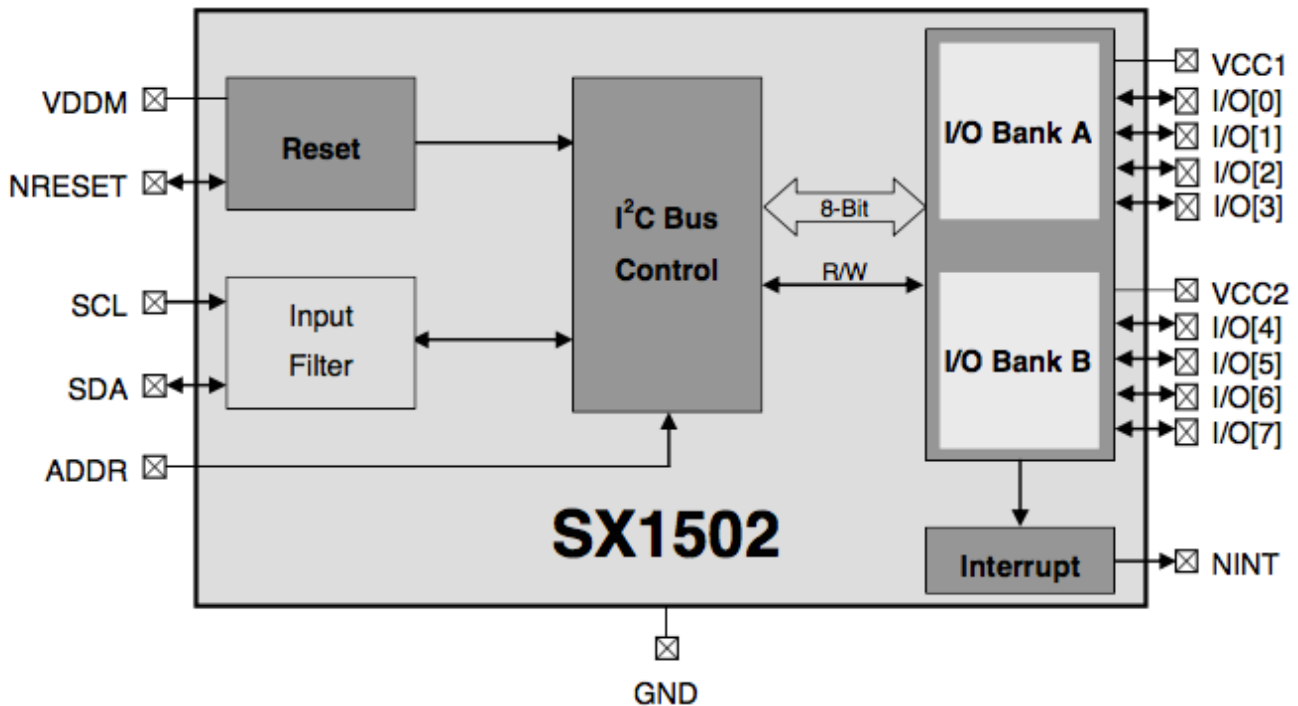

The SX1502 is a complete ultra low voltage General Purpose parallel Input/Output (GPIO) expanders ideal for low power handheld battery powered equipment. It allows easy serial expansion of I/O through a standard I2C interface. GPIO devices can provide additional control and monitoring when the microcontroller or chipset has insufficient I/O ports, or in systems where serial communication and control from a remote location is advantageous.

These devices can also act as a level shifter to connect a microcontroller running at one voltage level to a component running at a different voltage level. The core is operating as low as 1.2V while the I/O banks can operate between 1.2V and 5.5V independent of the core voltage and each other.

Each GPIO is programmable via 8-bit configuration registers. Data registers, direction registers, pull-up/pull-down registers, interrupt mask registers and interrupt registers allow the system master to allow the system master to program and configure 8 GPIOs using a 2 wire standard 400kHz I C interface.

PLD (Programmable Logic Device)

The SX1502 offers a unique fully programmable logic functions like a PLD to give more flexibility and reduce external logic gates used for standard applications. Pins IO4-IO7 are available for PLD use on the QPM board.

Since the whole truth table is fully programmable, the SX1502 can implement combinatory functions ranging from the basic AND/OR gates to the most complicated ones with up to four 3-to-1 PLDs or two 3-to-2 PLDs which can also be externally cascaded if needed.

In all cases, any IO not configured for PLD functionality retains its GPIO functionality while I/Os used by the PLD have their direction automatically set accordingly.

Please note that while RegDir corresponding bits are ignored for PLD operation they may still be set to input to access unused PLD inputs as normal GPI (PLD truth table can define some inputs to have no effect on PLD output) and/or generate interrupt based on any of the PLD inputs or outputs bits.

For more information, check out the SX1502 specification from Semtech.

Use in the QPM Board

As you can see in the block diagram in the previous section, the QPM solid state switches are controlled by IO0 -IO3 while IO4-IO7 are available on header JP5 as standard GPIO pins. Each of the QPM solid state switches has an indicator LED to show that the switch has been turned on.

FDC6330

The FDC6330L is an integrated load switch. The QPM board uses four of these devices, hooked up as four independent solid state relays. This device is particularly suited for compact power management in portable electronic equipment where 3V to 20V input and 2.3A output current capability are needed. This load switch integrates a small N-Channel power MOSFET (Q1) which drives a large P-Channel power MOSFET (Q2).

For more information, check out the DC6330L specification at <https://www.fairchildsemi.com/datasheets/FD/FDC6330L.pdf>

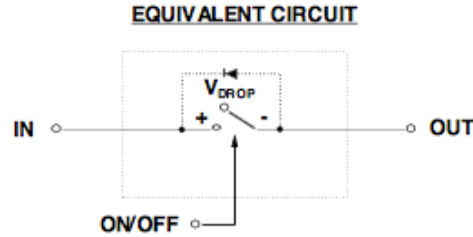
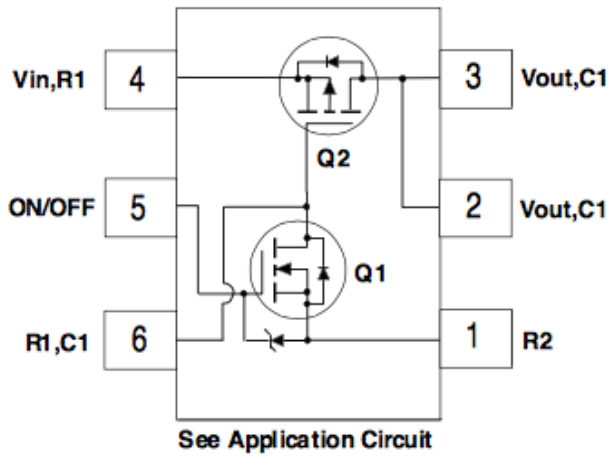

Operating Values

		Min	Normal	Max	Unit
VDDM	Supply Voltage	1.2		5.5	V
VCC1/VCC2	IO Supply Voltage	1.2		5.5	V
IOH	GPIO Output High Source Current			8 at VCC1/ VCC2 > 2V 0.3 at VCC1/ VCC2 < 2V	mA
IOL	GPIO Output High Source Current			12 at VCC1/ VCC2 > 2V 6 at VCC1/ VCC2 < 2V	mA
VSW	Input Voltage on LSW0-LSW3	3		20	V
ISWMax	Maximum Current through LSW0-LSW3			2.3	A

Pin Locations

Physical dimensions of board: 76 mm x 54 mm x 12mm(max).

I/O Key:

I - Digital Input
O - Digital Output
A - Analog

Pin Functions

JP1 - GPIO Bank 0/1 Voltage Supply

Used for connecting loads and power supply that are to be measured.

NAME	PIN	I/O	DESCRIPTION
VCC1	JP2 / 1	A	Supply for SX1502 IO pins 0-3 (connected to load switches). Usually tied to VDDM.
VCC2	JP2 / 2	A	Supply for SX1502 IO pins 4-7 (connected to load switches). Often tied to VDDM, but can be tied to 3.3V or 5.0V to provide level translation.

JP2 - Computer Side Pins

Input / Output Control Lines for Quad Power Management Board

NAME	PIN	I/O	DESCRIPTION
VDDM	JP2 / 1	A	Power for the Quad Power Management Board. Use 3.3V with Raspberry Pi and 5.0V with Arduino
GND	JP2 / 2	A	GND
SCL	JP2 / 3	I	Serial bus clock line; open-drain input.
SDA	JP2 / 4	I/O	Serial bus data line; open-drain input/output.
NINT	JP2 / 5	O	Outgoing Interrupt Line; 0 = Interrupt; open-drain output
NRES	JP2 / 6	I	Reset SX1502; open-drain input
ADDR	JP2 / 7	I	QPMB I2C Address Select - 0x21 if tied to VDDM, 0x20 if tied to GND. Default 0x21
GND	JP2 / 8	A	GND

JP3 - Auxiliary VDDM Pins

Auxiliary VDDM pins

NAME	PIN	I/O	DESCRIPTION
VDDM	JP3 / 1	A	Tied to VDDM input on JP2 (JP2/1)
VDDM	JP3 / 2	A	Tied to VDDM input on JP2 (JP2/1)

JP4 - Bank A/B Power Supplies

VCC1/VCC2 Power Supplies

NAME	PIN	I/O	DESCRIPTION
VCC1	JP4 / 1	A	Supply for SX1502 IO pins 0-3 (connected to drive Load Switch Control Lines) Usually tied to VDDM, but can be tied to 3.3V or 5.0V to provide level translation.
VCC2	JP4 / 2	A	Supply for SX1502 IO pins 4-7. Often tied to VDDM, but can be tied to 3.3V or 5.0V to provide level translation.

JP5 - Auxiliary GND Pins

Auxiliary GND pins

NAME	PIN	I/O	DESCRIPTION
GND	JP5 / 1	A	GND
GND	JP5 / 2	A	GND
GND	JP5 / 3	A	GND
GND	JP5 / 4	A	GND

LoadSwitch 0 (LSW0)*3 Pin Screw Terminal*

NAME	PIN	I/O	DESCRIPTION
DVIN0	LSW0 / 1	A	Diode Protected Input to LSW0
VIN0	LWS0 / 2	A	Input to LSW0
GND	LSW0 / 3	A	GND

2 Pin Screw Terminal

NAME	PIN	I/O	DESCRIPTION
VOUT0	LSW0 / 4	A	Load Switch 0 Output
GND	LSW0 / 5	A	GND

LoadSwitch 1 (LSW1)*3 Pin Screw Terminal*

NAME	PIN	I/O	DESCRIPTION
DVIN1	LSW1 / 1	A	Diode Protected Input to LSW1
VIN1	LWS1 / 2	A	Input to LSW1
GND	LSW1 / 3	A	GND

2 Pin Screw Terminal

NAME	PIN	I/O	DESCRIPTION
VOUT1	LSW1 / 4	A	Load Switch 1 Output
GND	LSW1 / 5	A	GND

LoadSwitch 2 (LSW2)

3 Pin Screw Terminal

NAME	PIN	I/O	DESCRIPTION
DVIN2	LSW2 / 1	A	Diode Protected Input to LSW2
VIN2	LWS2 / 2	A	Input to LSW2
GND	LSW2 / 3	A	GND

2 Pin Screw Terminal

NAME	PIN	I/O	DESCRIPTION
VOUT2	LSW2 / 4	A	Load Switch 2 Output
GND	LSW2 /	A	GND

LoadSwitch 3 (LSW3)

3 Pin Screw Terminal

NAME	PIN	I/O	DESCRIPTION
DVIN3	LSW3 / 1	A	Diode Protected Input to LSW3
VIN3	LWS3 / 2	A	Input to LSW3
GND	LSW3 / 3	A	GND

2 Pin Screw Terminal

NAME	PIN	I/O	DESCRIPTION
VOUT3	LSW3 / 4	A	Load Switch 3 Output
GND	LSW3 / 5	A	GND

Jumpers SJ1, SJ2, SJ3, SJ4

NAME	PIN	I/O	DESCRIPTION
SJ1		D	Connect to turn LSW0 ON on power up (Off is default)
SJ2		D	Connect to turn LSW1 ON on power up (Off is default)
SJ3		D	Connect to turn LSW2 ON on power up (Off is default)
SJ4		D	Connect to turn LSW3 ON on power up (Off is default)

Software for Arduino and Raspberry Pi

SwitchDoc Labs developed this pure Python Raspberry Pi library for this Quad Power Management Board as well as developing the Arduino C++ driver.

The Raspberry Pi software is located on the SwitchDoc Labs github under https://github.com/switchdoclabs/SDL_Pi_QPM.

Arduino drivers are also located on github under https://github.com/switchdoclabs/SDL_Arduino_QPM.

The first test on the Raspberry Pi should always be “i2cdetect -y 1” which should show you the QPMB at the default address of 0x21.

A similar test can be run on the Arduino (I2CTest - <http://playground.arduino.cc/Main/I2cScanner>).

Running the test results from the Quad Power Management board are below on the Raspberry Pi:

Test SDL_Pi_QPM Version 1.0 - SwitchDoc Labs

Sample uses 0x21 I2C Address
Cycles through all the four loadswitches
Program Started at:2015-08-04 23:51:44

```

-----
('----->>>> Initial GPIO Value =', 0)
-----
Turn on LSW0
Turn on LSW1
Turn on LSW2
Turn on LSW3

```

Turn on LSW0
Turn on LSW1
Turn on LSW2
Turn on LSW3

Turn on LSW0
Turn on LSW1
Turn on LSW2
Turn on LSW3

Turn on LSW0
Turn on LSW1
Turn on LSW2
Turn on LSW3

Next, here are the results of the QPMB test on the Arduino. This test cycles through turning on all of the Load Switches one by one, showing the LEDs flash. It also turns the GPIO IO7 on and off:

SDL_Arduino_QPM_Test
Version 1.1
----->>>> Initial GPIO Value =0

Turn on LSW0
Turn on LSW1
Turn on LSW2
Turn on LSW3

Turn on LSW0
Turn on LSW1
Turn on LSW2
Turn on LSW3

Turn on LSW0
Turn on LSW1
Turn on LSW2
Turn on LSW3

Turn on LSW0
Turn on LSW1
Turn on LSW2
Turn on LSW3

Applications

Applications

Applications of the QPM Board

The Quad Power Management board has many applications that come to mind. Any time you want to switch a battery out of the circuit, switch from one battery to another, turn power off to a device, stack and unstack batteries or turn power on or off to a device, this is your board.

The three applications below are from a new SwitchDoc Labs project, SunRover. SunRover is a semi-autonomous tracked robot that is being developed here in Washington state, but will eventually make it down to Curacao to join Project Curacao in the tropics.

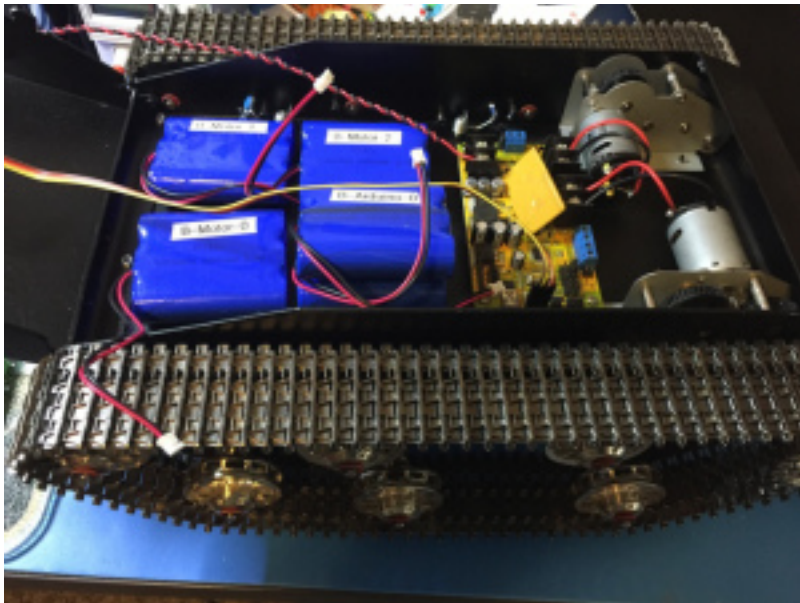

TRex Tracks, Controller and Batteries

SunRover has three computers. The first is the motor controller (TRex I2C controller made by Dagu) and connected to a Dagu set of robot TRex tracks.

The other two computers are an Arduino Mega 2560 (the power management computer – also does weather sensing) and the brains of SunRover, a Raspberry Pi 2 Quad Core computer.

The electronics will be packaged in a BUD enclosure as below. Note the Circuit Board Condo that we designed and 3D printed. It allows us to have three levels of PC boards in the box.

Application Examples

The three example applications for the QPM board are:

- Battery Stacker
- Solar Panel Multiplexer
- Robot Compartment Heater

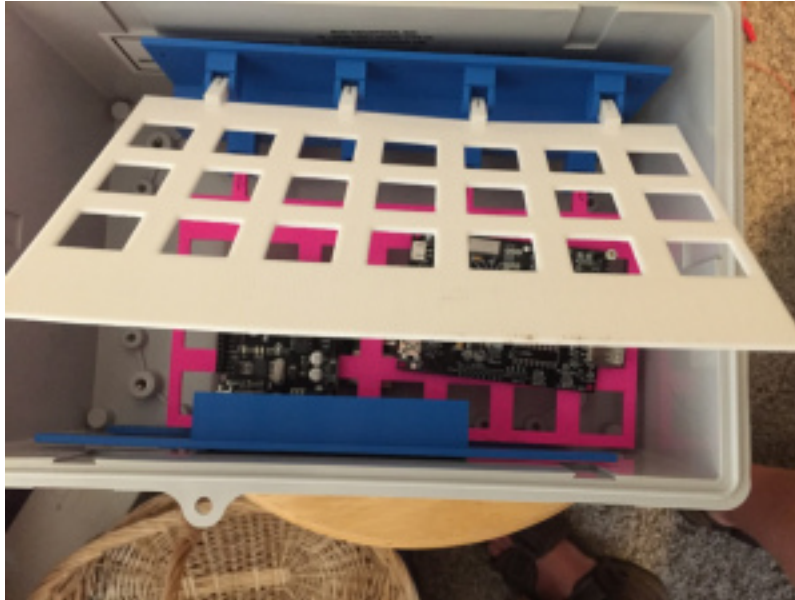

3D Printed Circuit Board Condo

Battery Stacker

To get the ~12V we need to run SunRovers motors, we need to stack 3.7V LiPo rechargeable batteries. It takes 3 batteries to get up to about ~12V.

The problem is that all of our Solar Powered Charging system is designed to charge 3.7V LiPo batteries. Our solution? Use two QPM boards to switch the batteries from a series to parallel connection and then charge the batteries from SunAirPlus. The QPM board even has two inputs per device. One with a protective diode and one without the diode. Perfect for our application.

LiPo Battery Stacker Quad Power Management Board Application

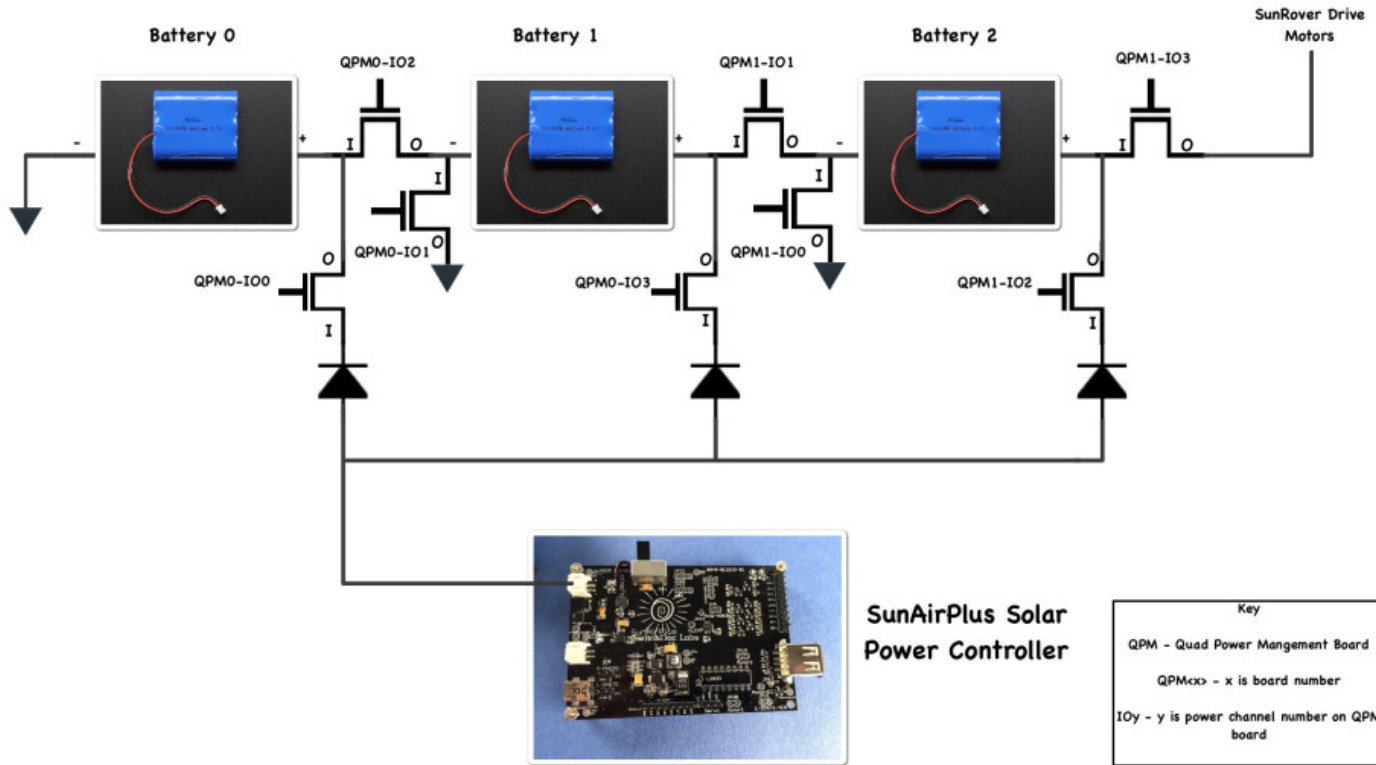

SwitchDoc Labs

Solar Panel Multiplexer

SunRover has 6 3.5W/6V solar panels. These will be on a “wing” across the top of SunRover. Each of these six solar panels can be switched by a Quad Power Management board and be connected in different ways to provide more power to the subsystem (Motors, Arduino or Raspberry Pi) depending on what needs it at the time and the Sun.

We are using four QPM boards to accomplish this.

SunRover Motors subsystem – up to 6 solar panels

Raspberry Pi subsystem – up to 4 solar panels

Arduino Power Management subsystem – up to 2 solar panels

QPM – Battery Stacker / Unstacker Applicaton

Solar Panel Muliplxer Quad Power Management Board Application

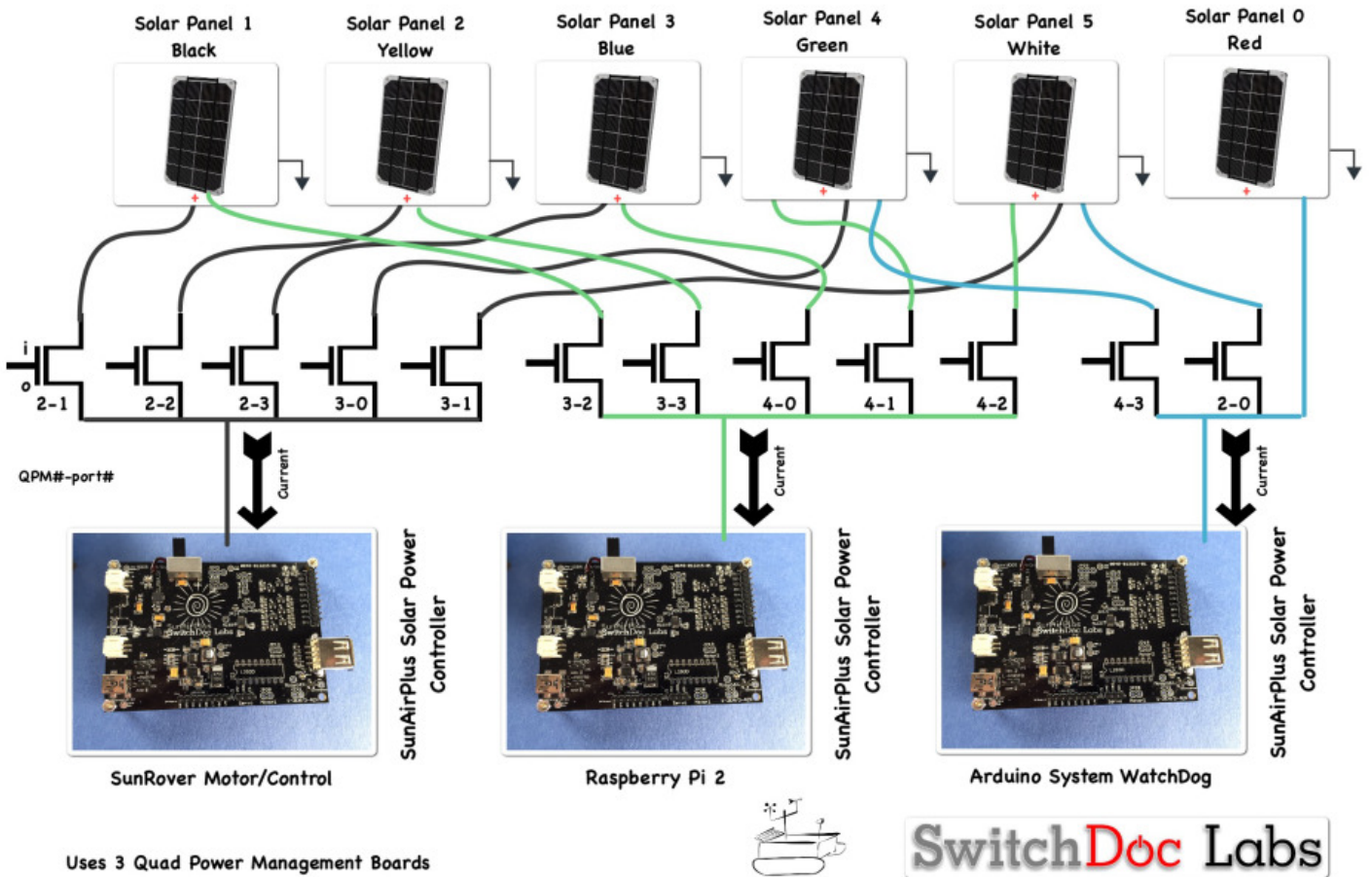

Robot Compartment Heater

Our third example application of the QPM board is a resistive compartment warmer. The winters are cold up here in the frozen north and LiPo batteries and electronics need to be kept warm to keep working. We are accomplishing this by using the QPM board to switch 10W/20 Ohm resistors, one in each compartment. We have temperature sensors in each compartment that will give us the feedback we need to moderate the heat sent to the resistors. How do we control the heat coming off of each resistor? We pulse the QPM switches to only power the resistor for the amount we need. If we want 3.6W, we turn the QPM switch on 1/2 of the time (7.2W/2). We can make it generate just enough heat to keep the compartment at the right temperature. Very cool. Or hot in this case.

Resistive Heater for Battery and Electronics Compartments Quad Power Management Board Application

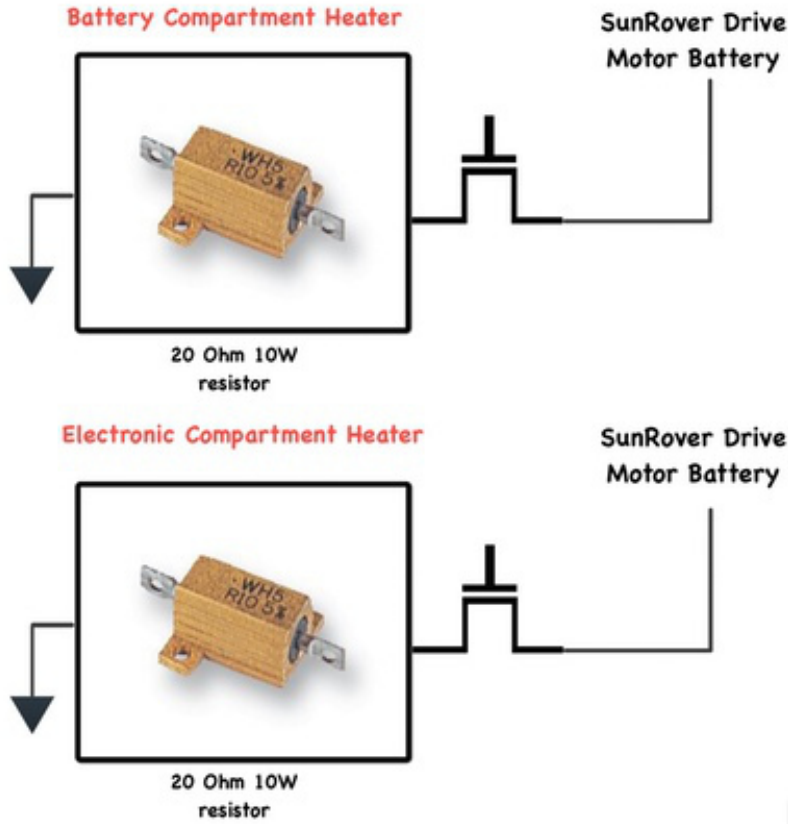

SwitchDoc Labs