

SwitchDoc Labs



SkyWeather Box Build and Weather Proofing Guide

May 2019

Version 1.4

Table of Contents

Errata	3
What is SkyWeather?	4
SkyWeather Features	4
Introduction to Building Your SkyWeather Outside Box.....	6
Versions of SkyWeather	6
SkyWeather Lite.....	6
SkyWeather Solar.....	6
SkyWeather Plus Solar WXLINK Remote	6
Before you Build your Outside Box	7
What do you need to Build your Outside Box?.....	8
What Parts do you need?	8
Tools and Supplies Needed.....	11
3D Printed Parts Needed.....	12
Assembly Instructions	14
Drilling Holes in the Bud Box	14
Tools needed	16
Vent Screen	20
Boards Placement	21
Sunlight and Camera housing	23
ThunderBoard Lightning Detection Housing	29
AM2315 Outside Temperature / Humidity Housing.....	31
Air Quality Sensor Housing.....	33
Inserting the Quartz Windows	35
Sealing the Box.....	36
Wiring the SkyWeather Box.....	38
RJ11 (Phone Cables)	38
Raspberry Pi Power Wiring.....	40
SkyWeather Wiring.....	41
Testing	41
The Science and Education Goals Behind SkyWeather.....	42
Support.....	42
Disclaimer	43

Errata

April 20, 2019 Veersion 1.2 – Fixed typos

May 29, 2018 Version 1.3 – Fixed Dimensions on top diagram

May 31, 2019 Version 1.4 – Improved mounting instructions for camera/sunlight detector and fixed typos.

What is SkyWeather?

This is a perfect project kit for kids with some help from the adults and for adults trying to learn some new things. We have done this before with our successful OurWeather KickStarter so we know what we are talking about. People all over the world have built the OurWeather weather station with great success. This project has **no soldering** involved and uses Grove connectors to wire everything up! You can't reverse them and blow things up. [Here is our tutorial on the Grove system.](#)

SkyWeather Features

- Barometric Pressure
- LIGHTNING!
- Outside Temperature
- Outside Humidity
- Altitude
- Inside Temperature (in box)
- Inside Humidity (in box)
- Air Quality - AQI (your own local Air Quality Sensor)
- Sunlight
- Wind Speed
- Wind Direction
- Rain
- All your weather information on the Cloud including history

Easy to build. Easy to learn about the IOT (Internet Of Things) and the Raspberry Pi.

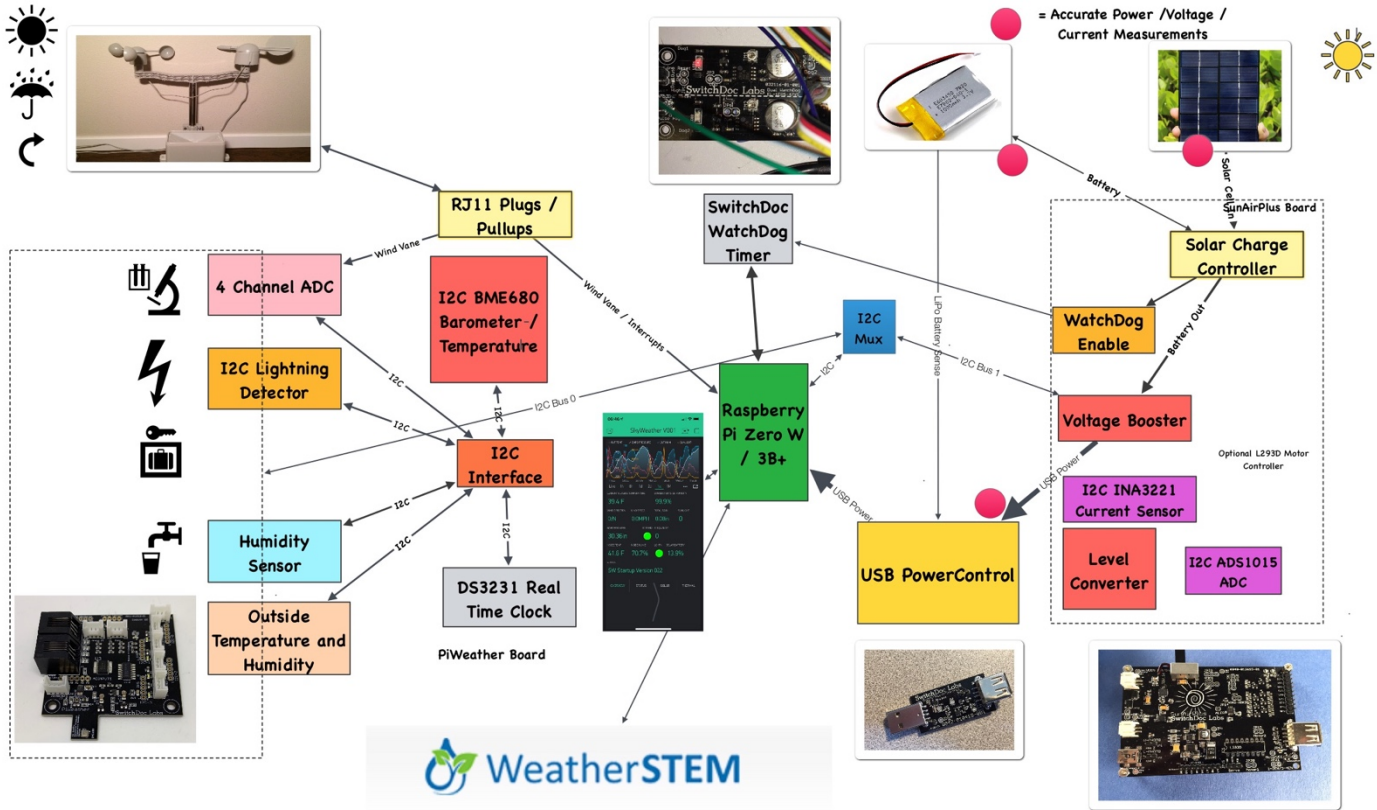

Introduction to Building Your SkyWeather Outside Box

In the SkyWeather Assembly and Testing manual, we showed you how to hook up and test all the hardware. In many cases, people will want to place the entire SkyWeather unit outside and it will need to be weatherproofed and put in an external box.

This manual is for building an outside enclosure for the SkyWeather Kit without Solar Panels. Below are comments applicable to our other SkyWeather Kits.

Why do we not supply all of these parts in a weatherproofing kit? Primarily shipping costs and the fact that the Bud Box is very tightly regulated for distribution. As volumes increase, we will revisit these issues. All the parts and links are below.

Versions of SkyWeather

SkyWeather Lite

SkyWeather Lite does not contain the Lightning Detector and the WeatherRack wind and rain sensors. Because of that, do not drill the holes for the Lightning Detector Pylon and you do not need to have the RJ11 box connectors for the WeatherRack

SkyWeather Solar

SkyWeather Solar adds a set of solar panels on the top of the SkyWeather Box. We have a special assembly manual for that add on to the SkyWeather kit. Note that you have to think about where and how to orient your solar panels versus the orientation you want for your Sky Camera. Solar Panels should generally point south (in the northern hemisphere) and north (in the southern hemisphere – right Topher?).

SkyWeather Plus Solar WXLink Remote

This SkyWeather package places the WeatherRack wind / rain sensors and the outside temperature and humidity sensor, along with a solar system in an external box connected by wireless LoRa. See the weatherproofing manual for the WXLink Box. Basically, you place the WeatherRack and the outside temperature / humidity sensors outside and the rest of SkyWeather can either be inside or outside. There are no wires between the WXLink remote box and the SkyWeather system. You may still want to place the Sky Camera and SkyWeather system outside and in that case you do not need to have the RJ11 box connectors for the WeatherRack or the hole AM2315 Outside Temperature and Humidity Sensor.

Before you Build your Outside Box

Before you weatherproof your SkyWeather box, hook up the entire project as indicated in the SkyWeather Assembly Manual and run all the tests. It is much easier to find your problems before you put it into the box!

What do you need to Build your Outside Box?

There are many, many ways of building a weatherproof box for SkyWeather. What you do will depend on where you are putting the kit and what version you are building. The below parts are for the full SkyWeather non solar kit.

What Parts do you need?

To build a weatherproof SkyWeather box, here is the suggested list of parts. Note: These are suggestions. All of these parts have multiple versions that will work just fine.



Part A - One of - Bud Box Enclosure - BUD Industries NBB-22241 Style B Plastic NEMA Box with Solid Indoor, 10-23/32" Length x 6-25/32" Width x 4-21/64" Height

<https://amzn.to/2DdP6RU>



Part B - Two of - Anmbest Panel Mounting Shielded RJ45 Waterproof Cat5/5e/6 8P8C Connector Ethernet LAN Cable Connector Double Head Coupler Adapter Female to Female with Waterproof/Dust Cap

<https://amzn.to/2X9YAVx>

<https://amzn.to/2IkQkPI>



Part C -One of - USB Female Socket Plug Panel Mount Adapter USB 3.0 Waterproof Connector IP67

<https://amzn.to/2DeQNOR>

<https://www.ebay.com/itm/USB-Female-Socket-Plug-Panel-Mount-Adapter-USB-3-0-Waterproof-Connector-IP67/113201047236?ssPageName=STRK%3AMEBIDX%3AIT&var=413500490069&trksid=p2060353.m2749.l2649>



Part D - M3 Mylon Hex Thread Assortment Kit

<https://shop.switchdoc.com/collections/shop-all/products/120pcs-box-m3-nylon-hex-thread-assortment-kit>

<https://amzn.to/2ItPsqG>

<https://www.ebay.com/itm/120pcs-box-M3-Nylon-Hex-Thread-Assortment-Kit/163193216844?epid=20022373536&hash=item25ff12df4c:g:CCgAAOSwMv5ba37t>



Part E – One box of - M2 White Nylon Spacers Hex Nut Screw Stand-off Plastic Accesories Assortment Kit (there are some boards that require the smaller screws)

<https://amzn.to/2X8gzM8>

<https://www.ebay.com/itm/M2-Nylon-Hex-Spacers-Screw-Nut-Assortment-Kit-Stand-off-Plastic-Accessories-Set/301828057527?epid=1293432691&hash=item46465aa9b7:g:L3kAAOSwxN5WbilT>

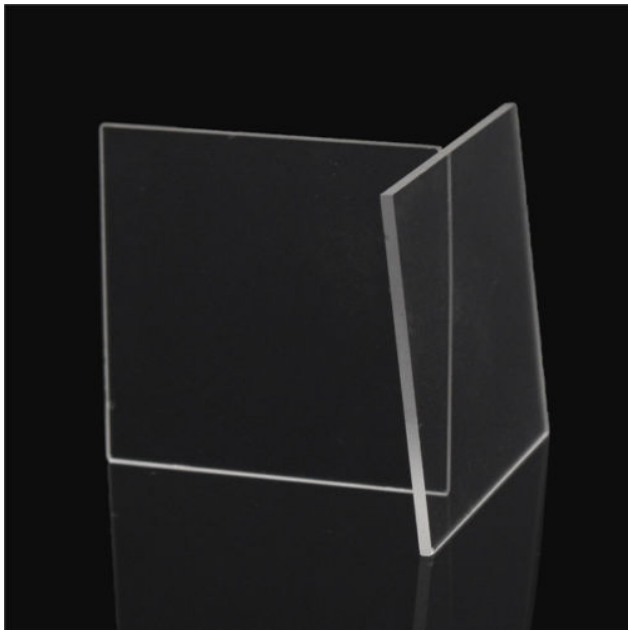

Part F – Two of - Double Side Polished Far-UV Fused Silica Quartz Glass Sheets Plate 30*30*1mm – (Strictly speaking you can use plastic for the camera shield, but it is required for the sunlight sensor)

<https://shop.switchdoc.com/products/double-side-polished-far-uv-fused-silica-quartz-glass-sheets-plate-30-30-1mm>

https://www.ebay.com/itm/3x-Double-Side-Polished-JGS1-Fused-Silica-Quartz-Glass-Sheets-Plate-30x-30-x-1mm/372605446864?_trkparms=aid%3D555018%26algo%3DPL.SIM%26ao%3D1%26asc%3D20190212102350%26meid%3D5550fad816bf48b191ec220386f33756%26pid%3D100012%26rk%3D2%26rkt%3D12%26sd%3D172299329324%26itm%3D372605446864&_trksid=p2047675.c100012.m1985

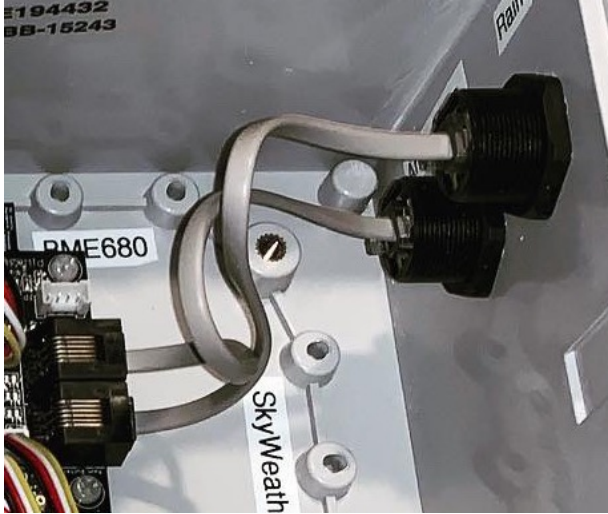

Part G – Two Short RJ11 Straight Wired Phone Cables (or buy a cheap building kit and make your own)

Local hardware store

If you want to build your own - For Cable Building Kit:

25 foot Telephone Cord – (this is for raw materials)

<https://amzn.to/2UyuzlD>

Cable Building Kit (contains tester!):

<https://amzn.to/2XcYEDU>

Tools and Supplies Needed

- **Drill including up to 1” router bits**
- **Super Glue**
- **Screwdrivers**
- **Silicon Caulking**

3D Printed Parts Needed

(these are suggestions – Feel free to design more!)

We do provide 3D Printed parts if you don't have a printer, but we recommend you print your own.

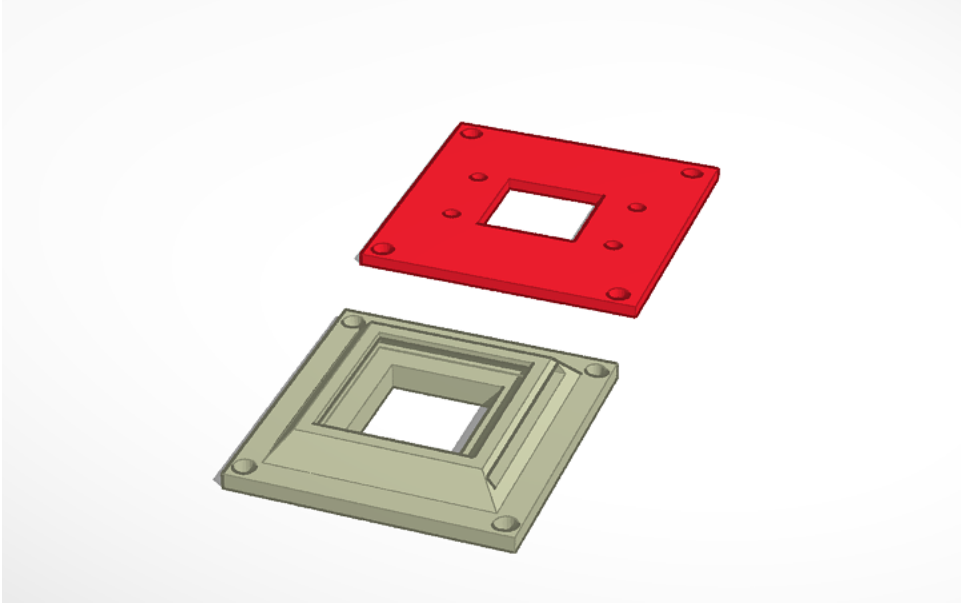

Quartz Window and base for Sunlight Sensor and Camera (you need two!)

<https://www.tinkercad.com/things/cO1s0mSQRfV>

Air Quality Sensor Housing

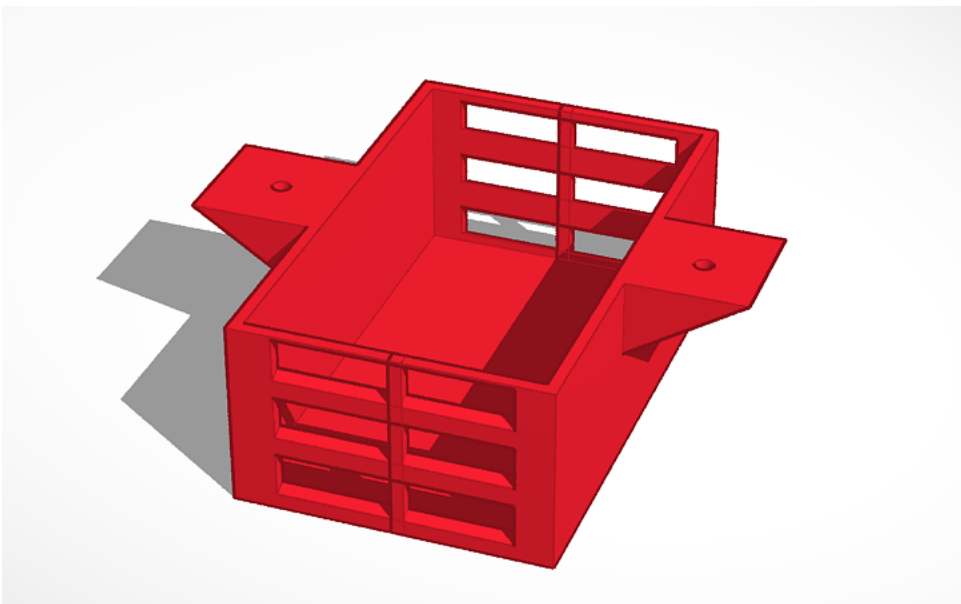

AM2315 Outside Temperature Humidity Sun Shield and Lightning Pylon

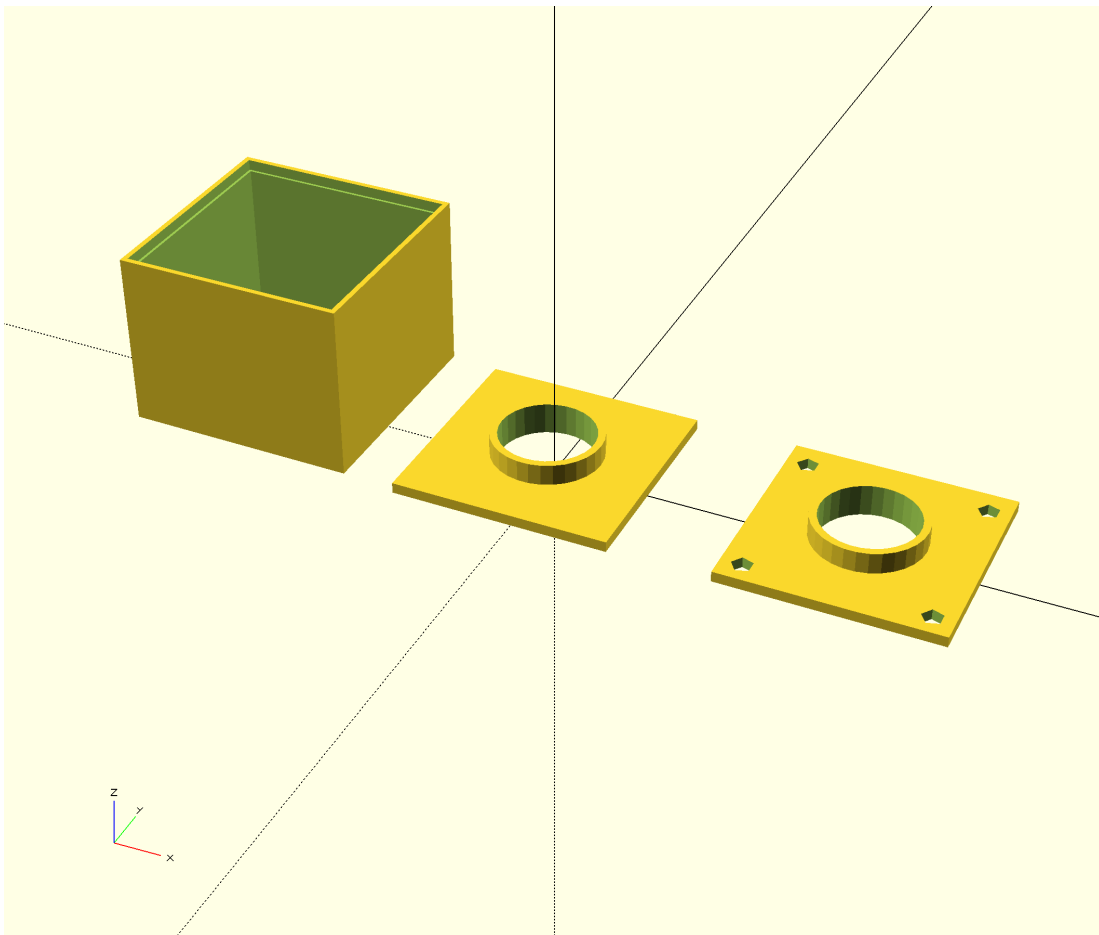
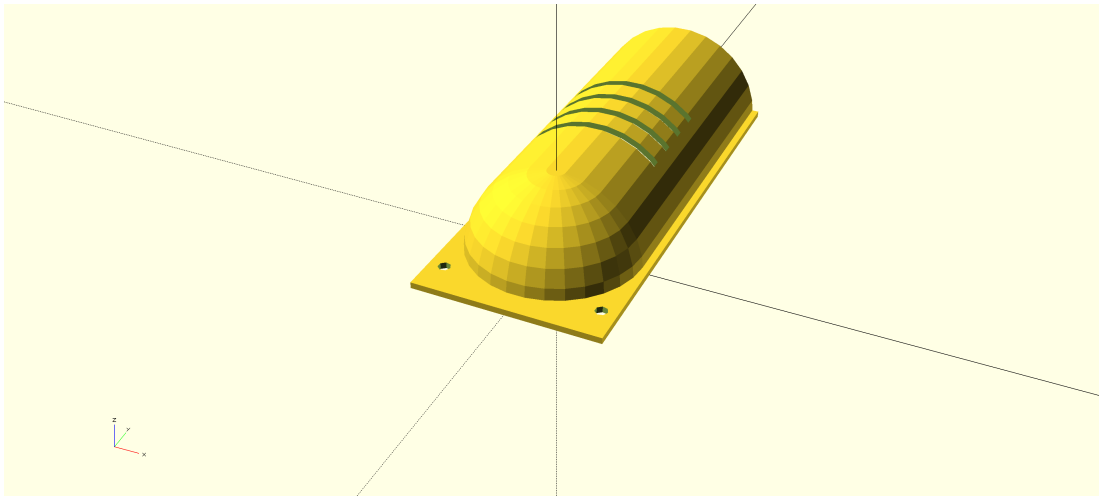

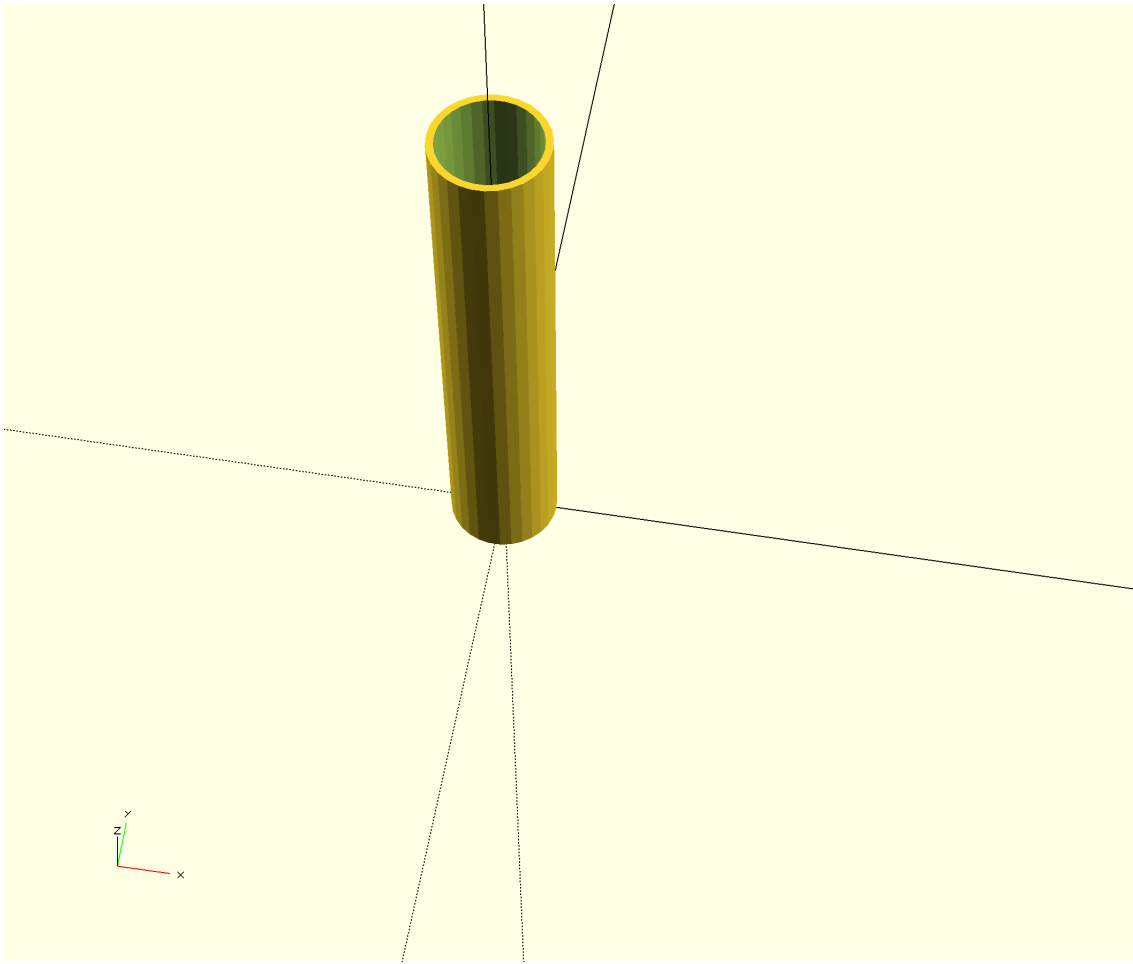

<https://github.com/switchdoclabs/SkyWeatherPylonSunShade3DParts>

Assembly Instructions

Cautions: Keep your static charge to a minimum during your assembly and operation. Touch metal before handling parts. Avoid shuffling your feet. Before starting assembly, layout all the parts above and familiarize yourself with the various parts.

Drilling Holes in the Bud Box

This is the most difficult part of the assembly. You will be drilling holes in the bottom of the Bud box, the front and both sides. No holes are drilled in the top or back of the bud box.



Tools needed



Bottom Face

Here we will drill seven holes. Two screw holes for the Air Quality box mounting, one for the Air Quality Grove cable, two holes for the RJ11 WeatherRack plugs, one hole for the External USB Power Plug and a hole for the vent. All measurements are from end of rounded edge on the Bud Box (the end of the lip on the bottom) to center of hole to be drilled. All measurements are in millimeters. Remember 25.4 mm = 1.0 inch.

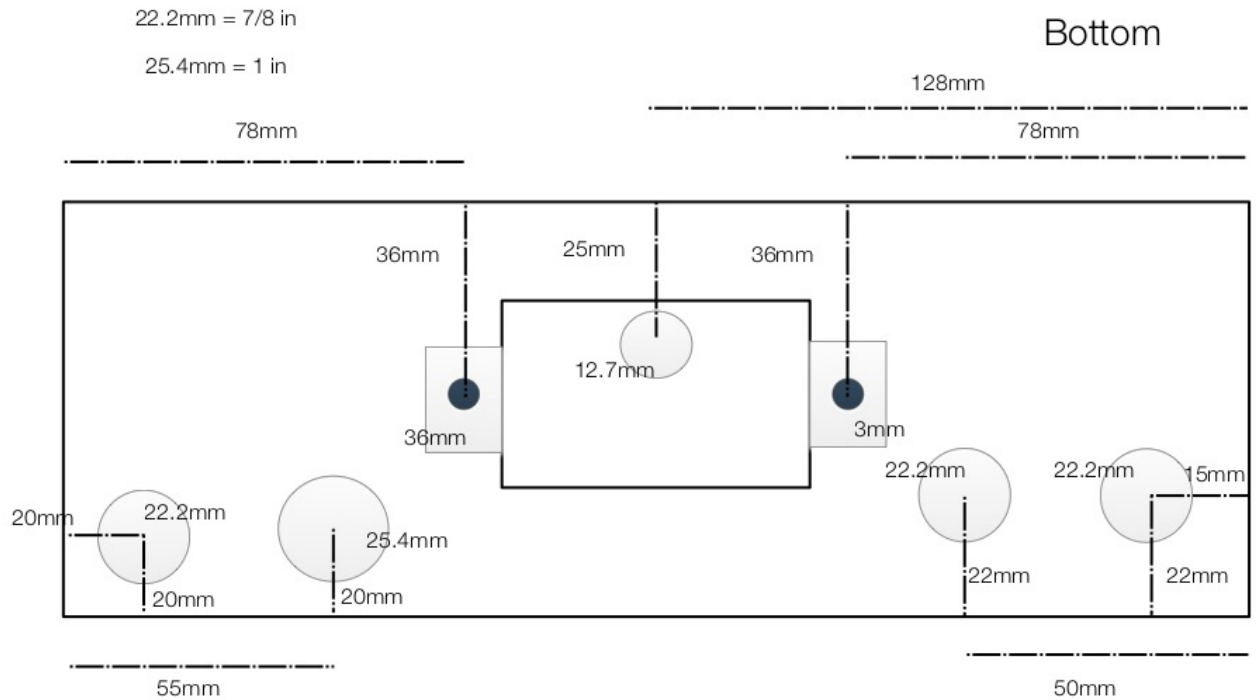

Left and Right Facing Side

There are five holes on the LEFT for the Outside Temperature and Humidity Sensor Sun Shade Housing. Four for mounting screws and one 1/2 inch hole (12.7mm) for the Grove cable.

On the RIGHT side, there are four mounting holes and the 1/2 inch hole (12.7mm) for the Grove cable.

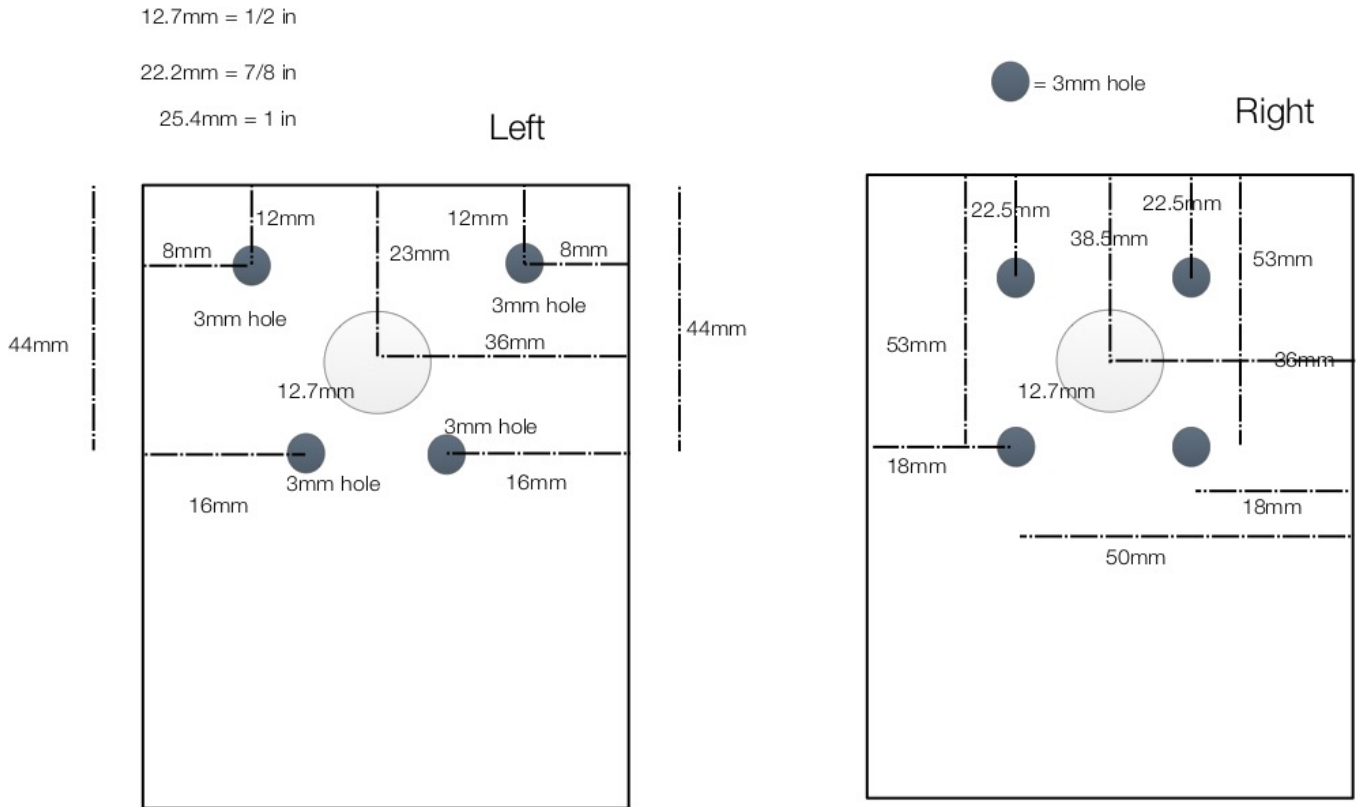

Top

On the Top of the box, you will drill a total of two 1 inch (25.4mm) holes and eight 3mm screw holes. The camera will go on the left and the sunlight sensor will go on the right.

22.2mm = 7/8 in

25.4mm = 1 in

● = 3mm

Top

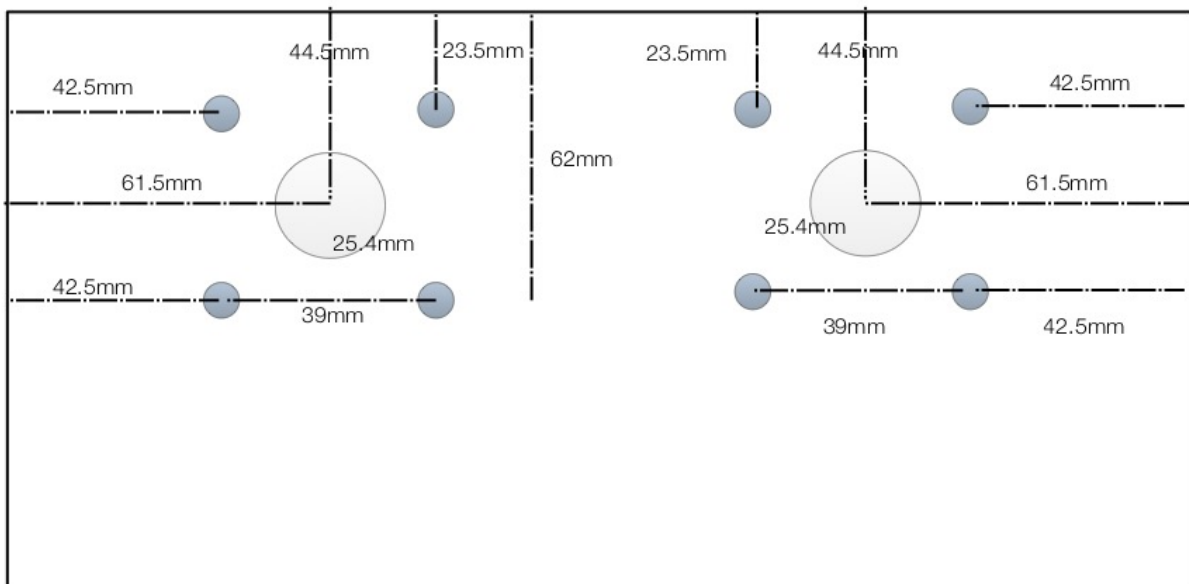

Take your two RJ11 Panel mounts and screw them into the right side of the bottom plate of the box and then take the remaining USB connector and screw it into the second from the left hole.



Vent Screen

Take a small piece of screen door material and use silicon caulking to seal the Vent so small insects won't colonize your SkyWeather system.

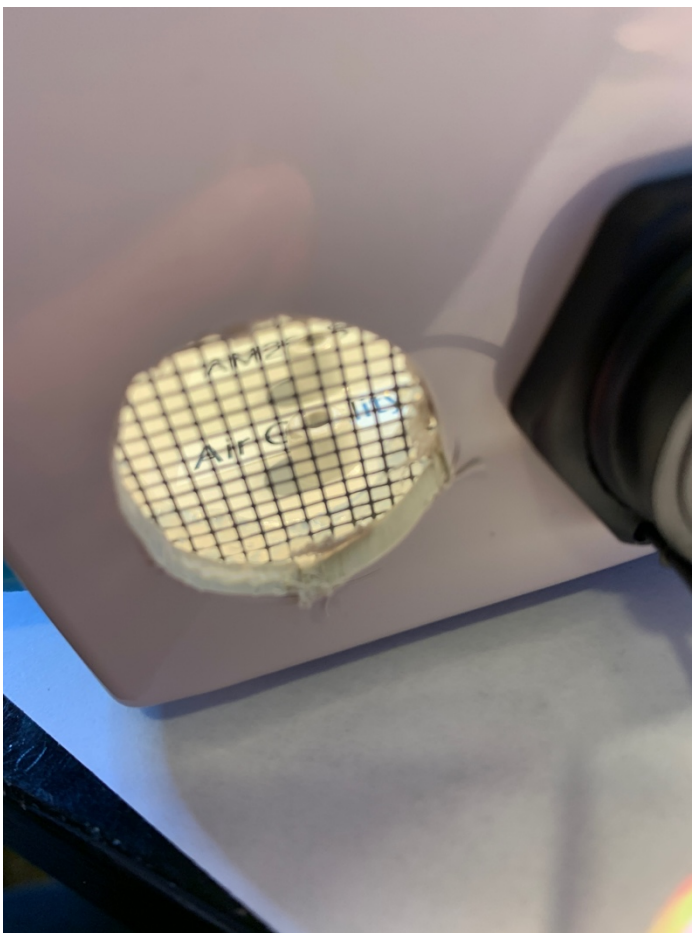

Now you are ready to start placing the 3D printed housings, boards and parts.

Boards Placement

Take the boards provided for SkyWeather and place plastic posts (some will take M2 screws and posts and some will take M3 screws and posts) on each and secure them with screws. For the Grove PowerSave boards, super glue an additional post as shown:

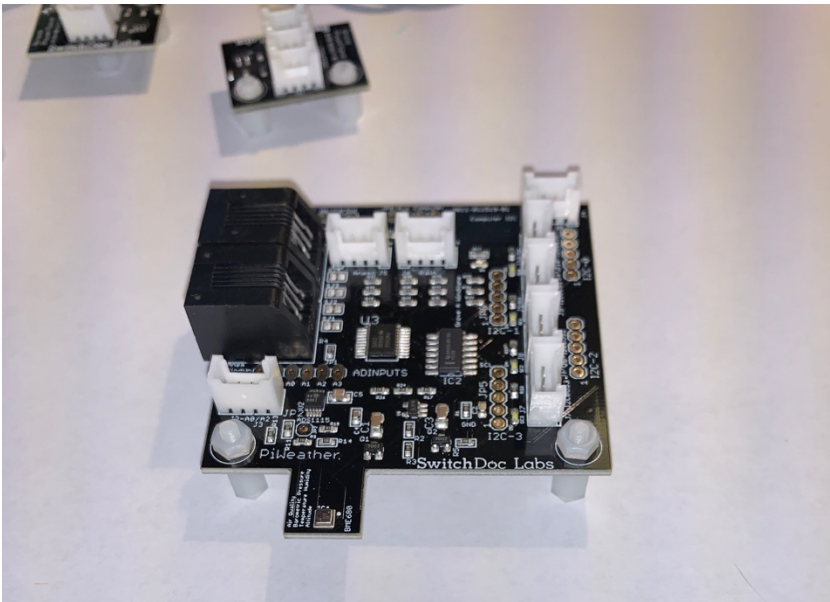
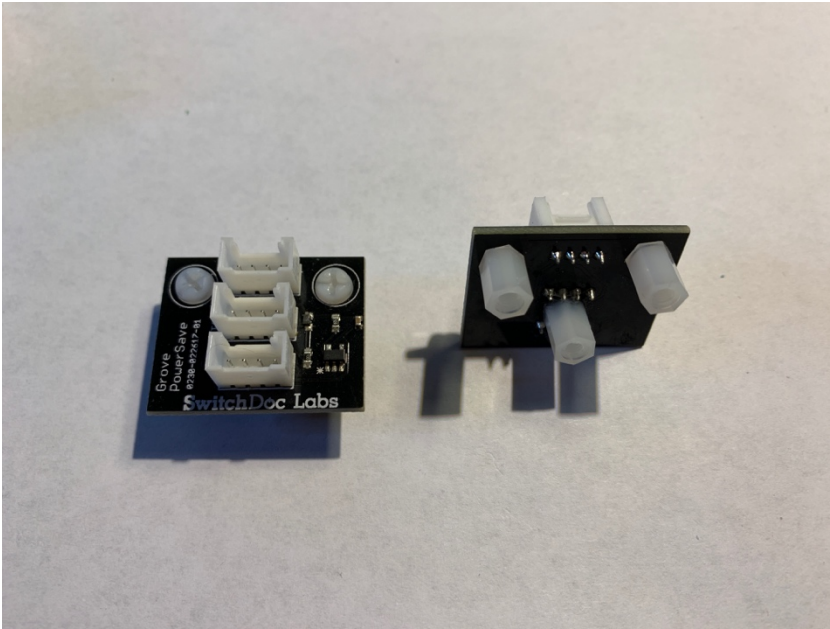

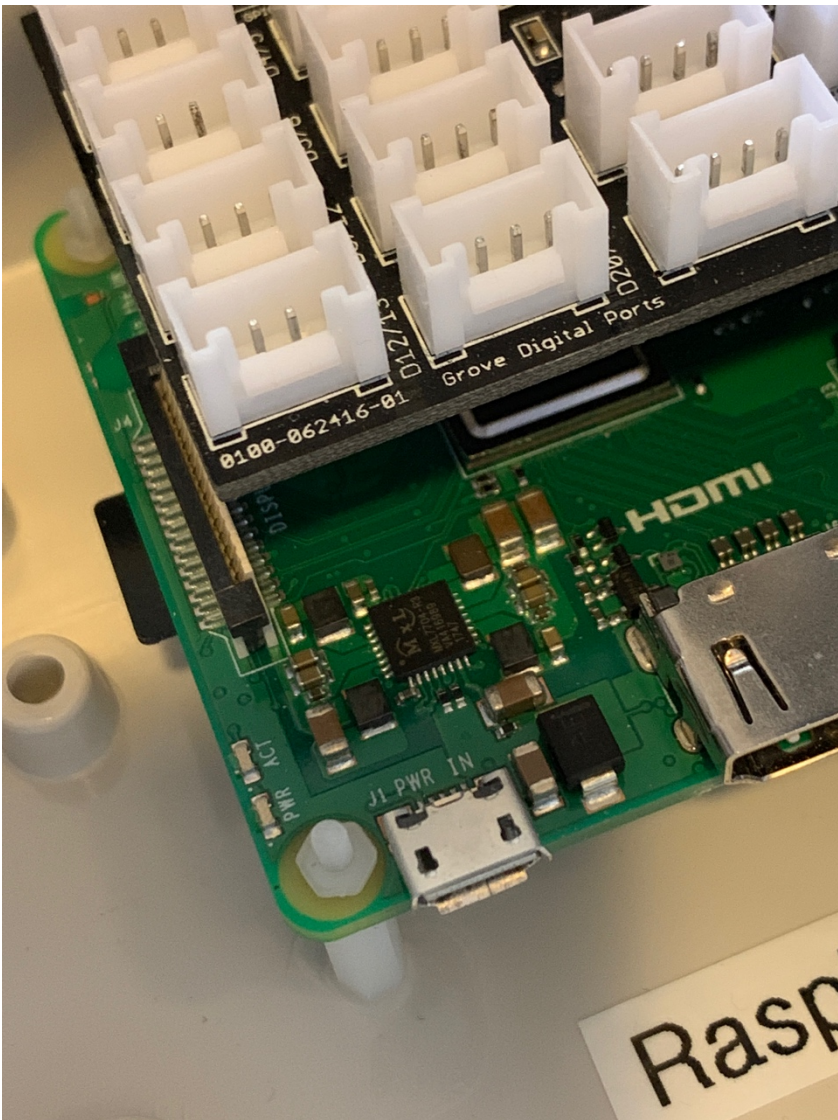
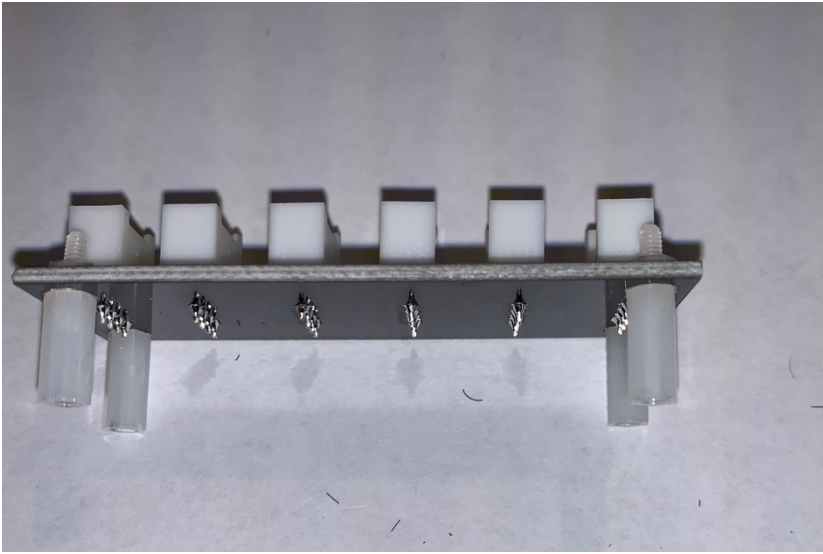

Now that you have all the posts attached, super glue each board in place inside the enclosure as follows and then let dry. Note: If you are using a Raspberry Pi Zero W, you will want to mount the Raspberry Pi Zero on the the back of the box (above the Raspberry Pi 3 below) because of the length of the supplied Raspberry Pi Zero camera cable. Otherwise, you can buy a longer cable for the Raspberry Pi Zero.

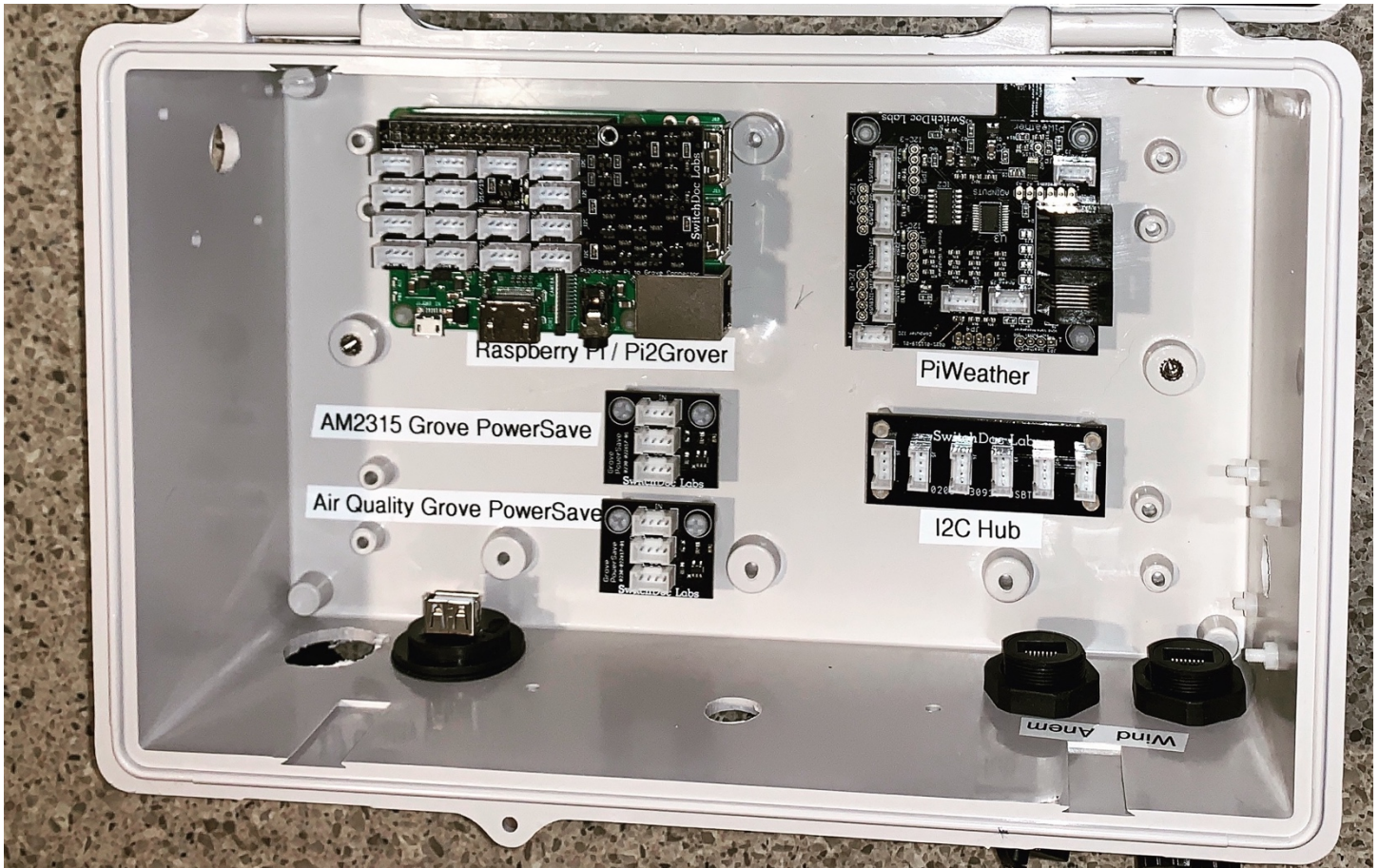

Sunlight and Camera housing

First attach short posts on the camera sensor base.

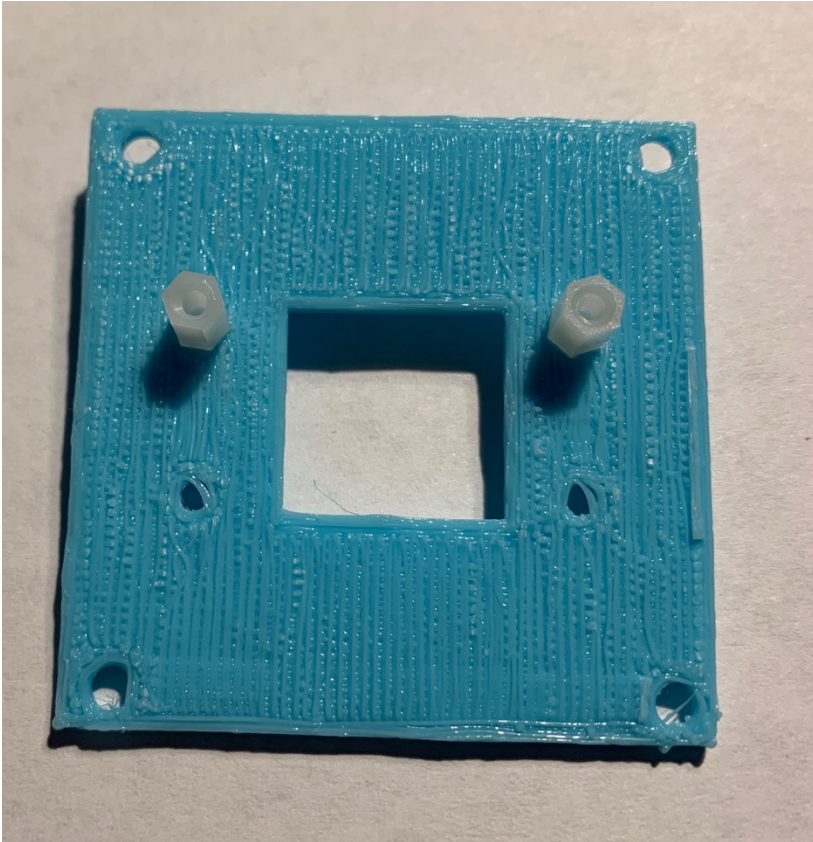

Then connect the camera to this base using screws with the camera facing up. Next connect the Raspberry Pi Camera cable to the camera. Blue side of the cable faces up.

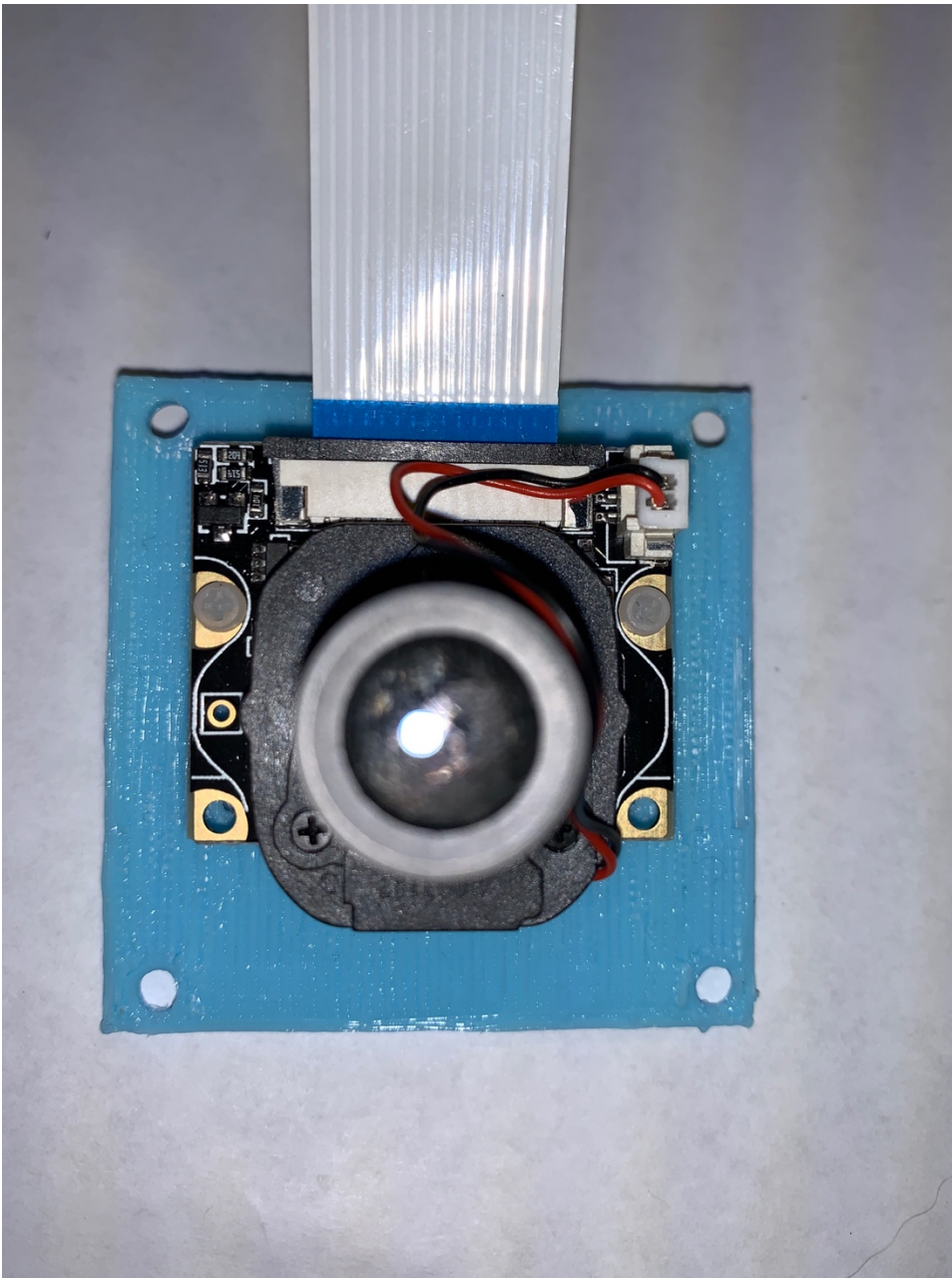

Next, take the other base housing and screw the Sunlight Sensor to the base facing up with the Grove connector facing down. Note: This picture shows a SI1145 sunlight sensor. SkyWeather uses a board utilizing the TSL2591 that has the same form factor.

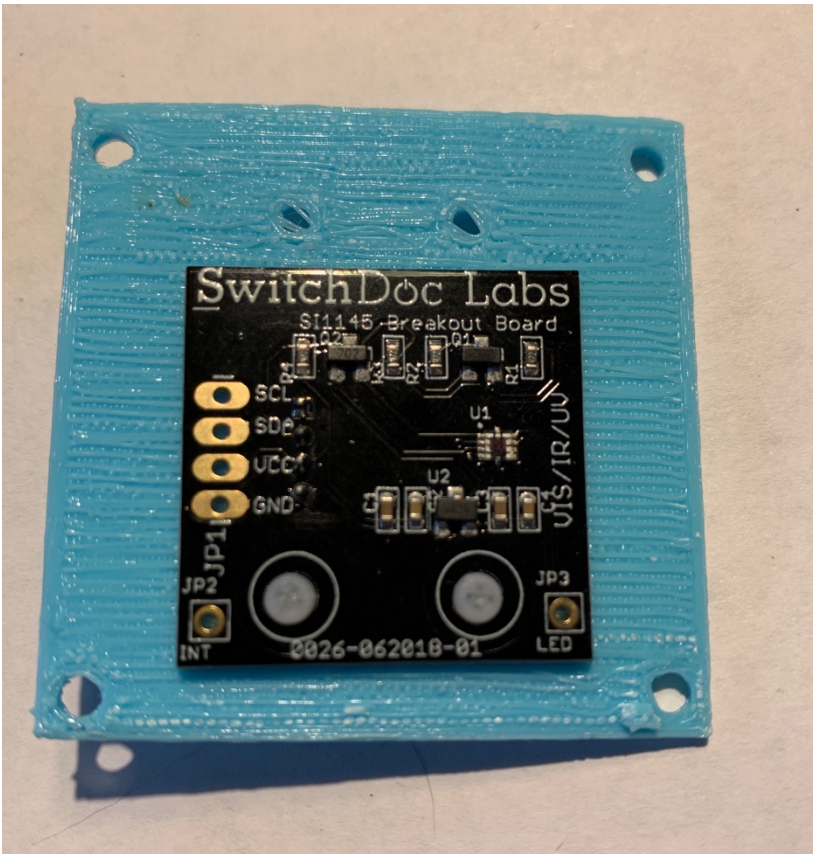

Next take two medium height posts, screw them together and attach to the inside of the box on the left side of the top. Put the screws through the outside housing for the camera and use nuts to connect them. Repeat this for each corner of the camera holes. Note that you have now attached the outside camera housing (that you will slide plastic or quartz into later) to the outside of the box.

Note: If you do not have long enough screws, super glue the posts with the threads into the Box and then glue them into the outside housing. Put your housing open slot for the crystal facing towards the front of the box. Then use screws to connect them to the base unit below.

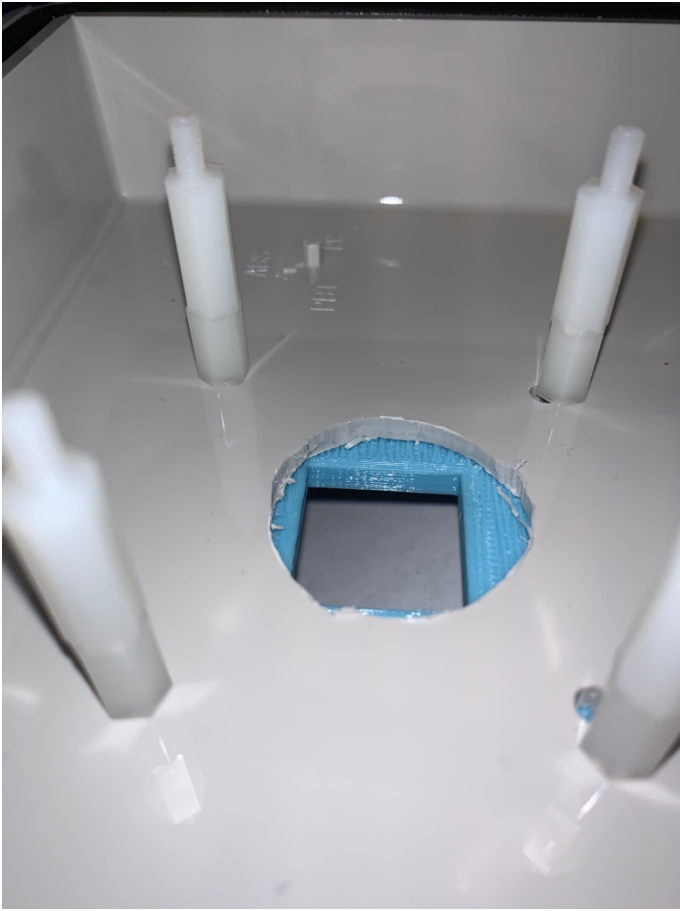

If your plastic screws are too long, then clip them with a wire clipper to make them an appropriate length. Repeat the same process on the sunlight side (right side of the front panel) except use short posts. Use the same fix if you do not have long enough screws



Now snap the two sensor base plates into place over the shafts of the standoff posts. Camera on the left, Sunlight sensor on the right. Both should face down into the holes.

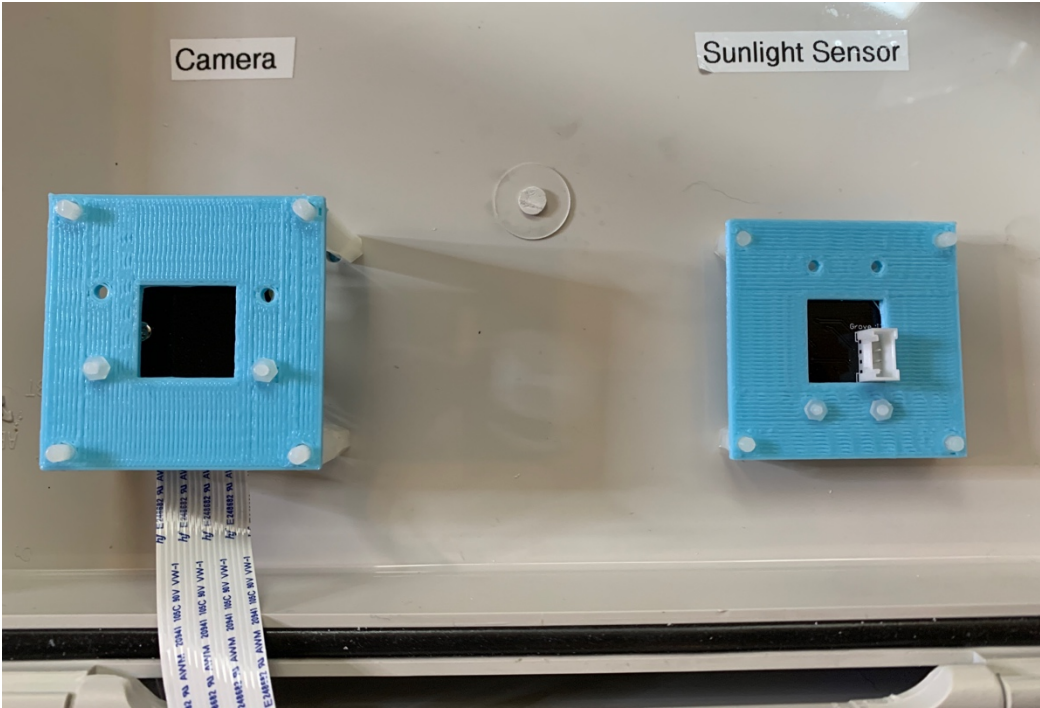

This completes the Camera and Sunlight sensor housing placement.

ThunderBoard Lightning Detection Housing

Attach the base of the Lightning housing to the right panel of the box using four screws and nuts.



Now take your ThunderBoard Lightning detector and plug the two 50cm Grove cables into the Grove connectors and thread your wires through the remain parts of the Lightning housing.

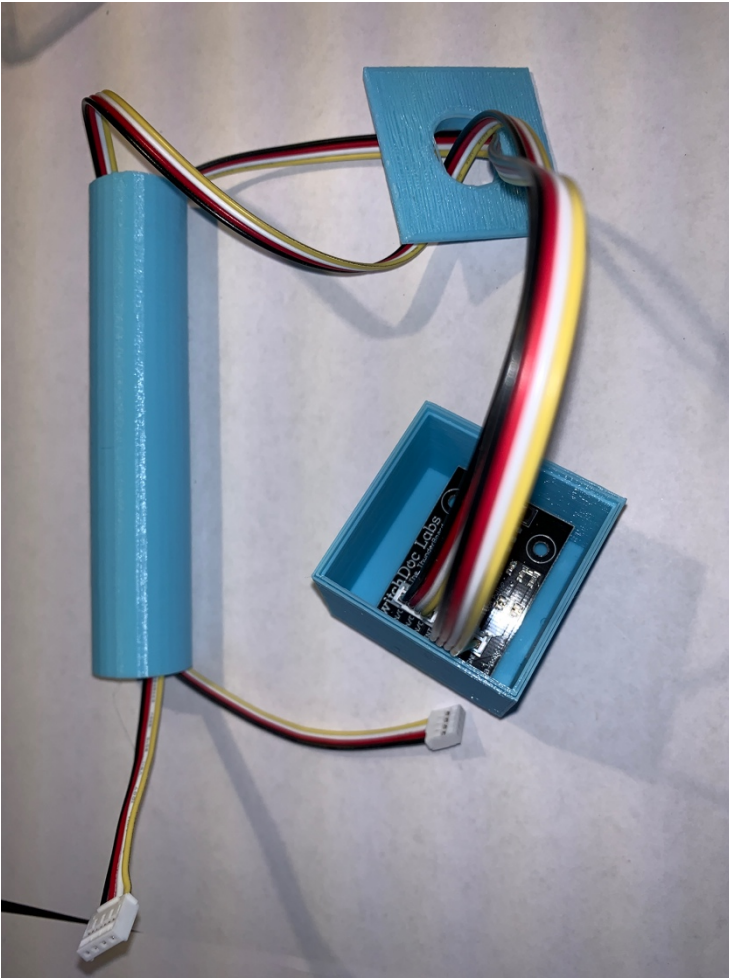

Now assemble the housing and place it on the side of the box. Any fittings that are a little too tight, use a file to file down the parts so they fit. Any that are too loose, use some super glue to figure it out. Put a piece of tape on the I2C grove cable to keep track of which one the I2C cable is during your wiring.

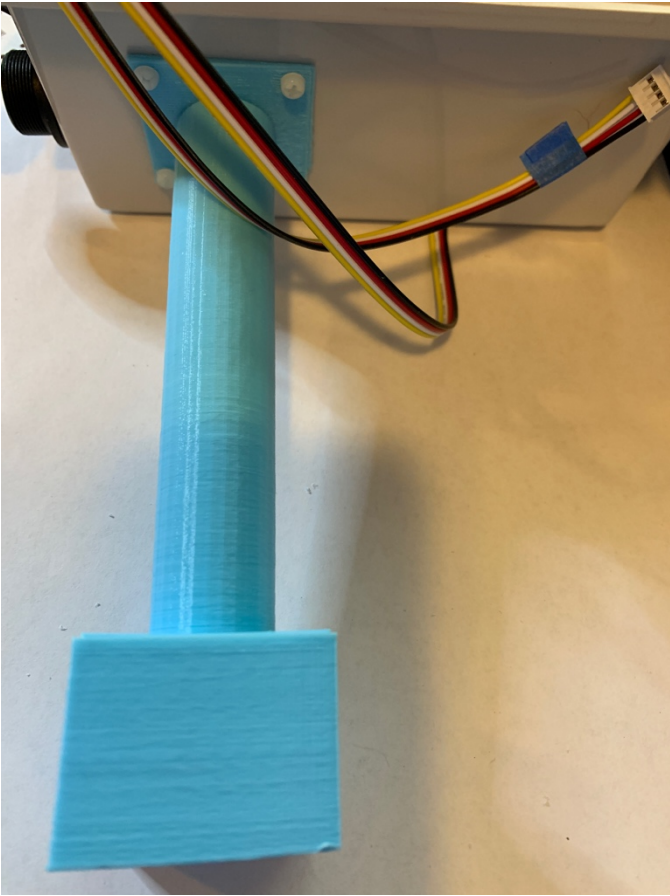

AM2315 Outside Temperature / Humidity Housing

Take the plastic clip from your AM2315 Outside Temperature / Humidity sensor and mount it on the outside of the enclosure on the left panel using screws and bolts. Remember that this sensor does need to be covered. It is water resistant, but not water proof.



Next, take your AM2315 and route the Grove cable into the hole above the clip and snap the AM2315 in place.



Finally, attach the Sun Shade housing over the AM2315 with two screws and bolts at the top. If you can't put a bolt on the bottom screw then super glue the screw in the hole in the enclosure.



One last note about the Outdoor Temperature and Humidity sensor. If you find that the sun shade on the box is in the sun too much and affects the temperature too much, feel free to move it to another location where is out of the sun.

Air Quality Sensor Housing

Finally to our last external housing, outside Air Quality housing. Take your Grove Air Quality Dust Sensor and place it as shown all the way down in the housing. If it is loose, then apply some super glue to the edges.

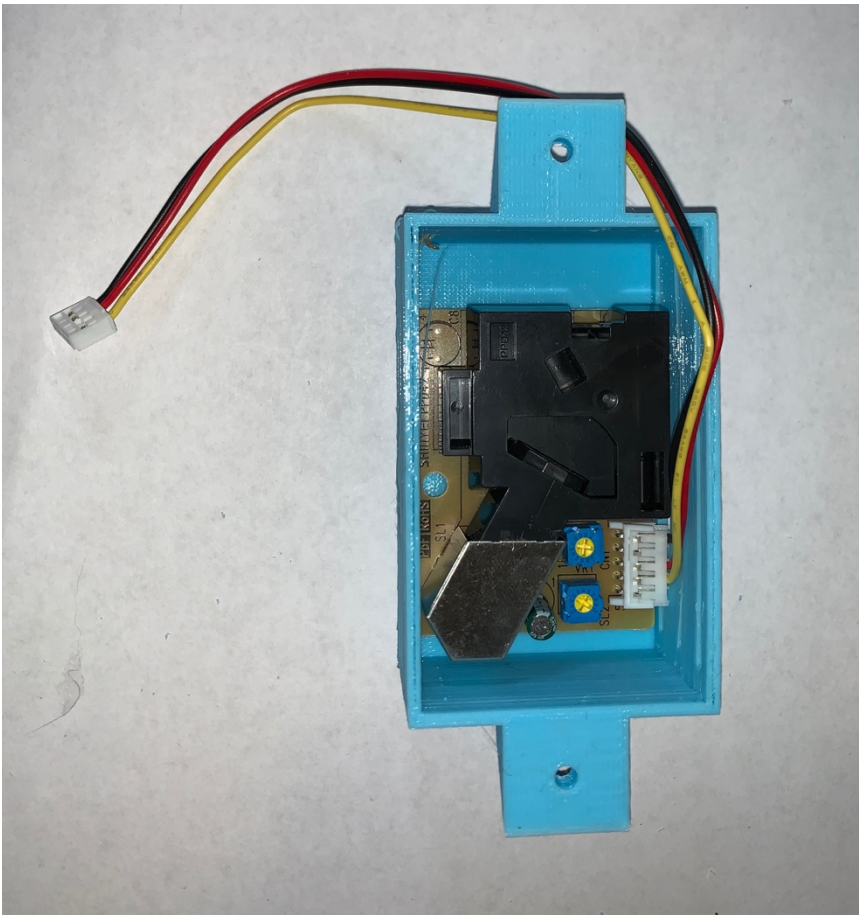

Next, route the Grove cable in through the provided hole on the bottom panel of the enclosure and attach the Air Quality housing to the bottom panel of the enclosure using screws and nuts.

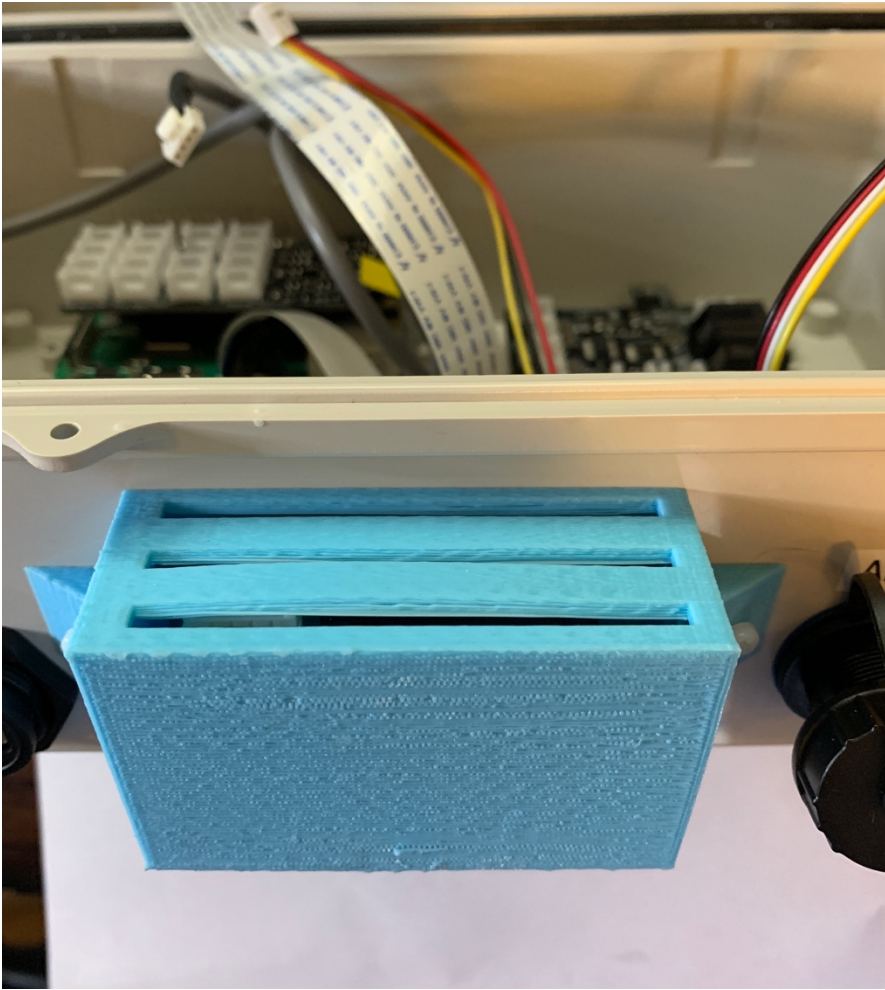

Inserting the Quartz Windows

Take the 30m x 30m x 1 quartz windows and slide them into the outside housings for the camera and the sunlight sensor. If the don't slide in well, clean the channels with a small screwdriver first.

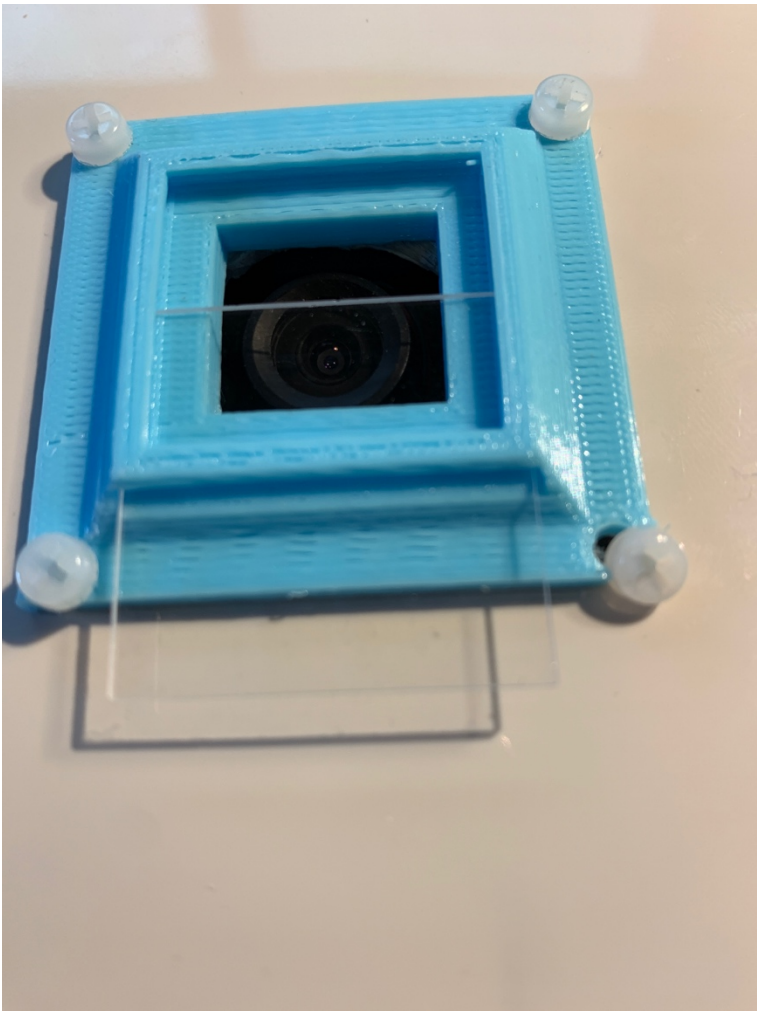

Sealing the Box

Use silicon caulking (or similar sealant) and seal all the outside holes and around the housings. Remember to carefully (use a toothpick) seal the edges of the quartz windows.

Fill the holes that you have run Grove wires through for extra security.



And the completed SkyWeather box ready for wiring.

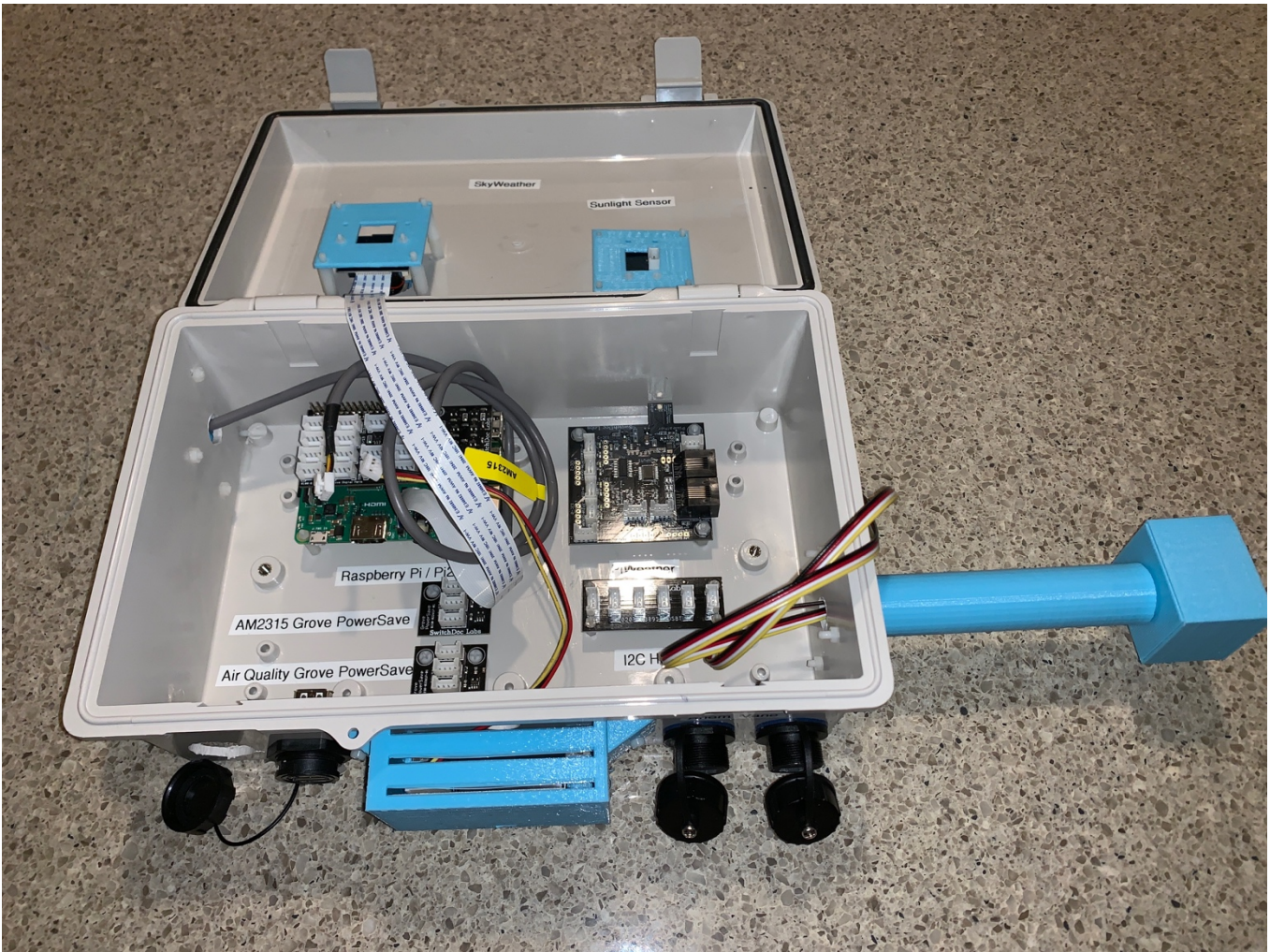

Wiring the SkyWeather Box

The majority of the wiring instructions for SkyWeather are identical to those in the “SkyWeather Assembly and Testing Manual” with one exception, that of the additional RJ11 cables.

RJ11 (Phone Cables)

You can either build your own cables or go to a local hardware store and purchase two short RJ11 cables. If you do purchase a set of short cables, make sure they have at least four wires and are wired straight as shown in the picture below.

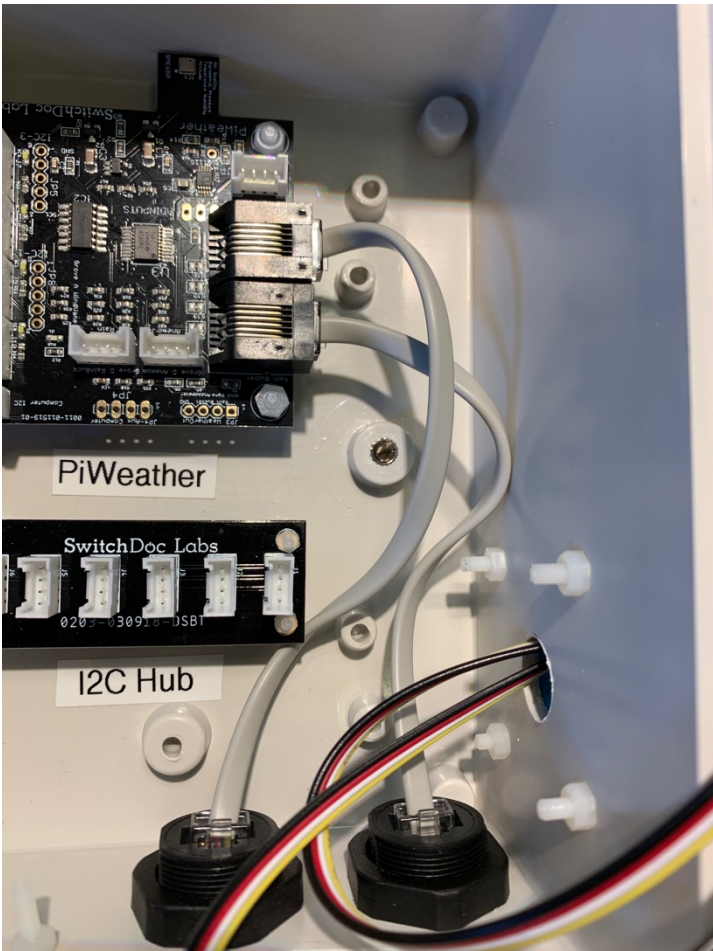
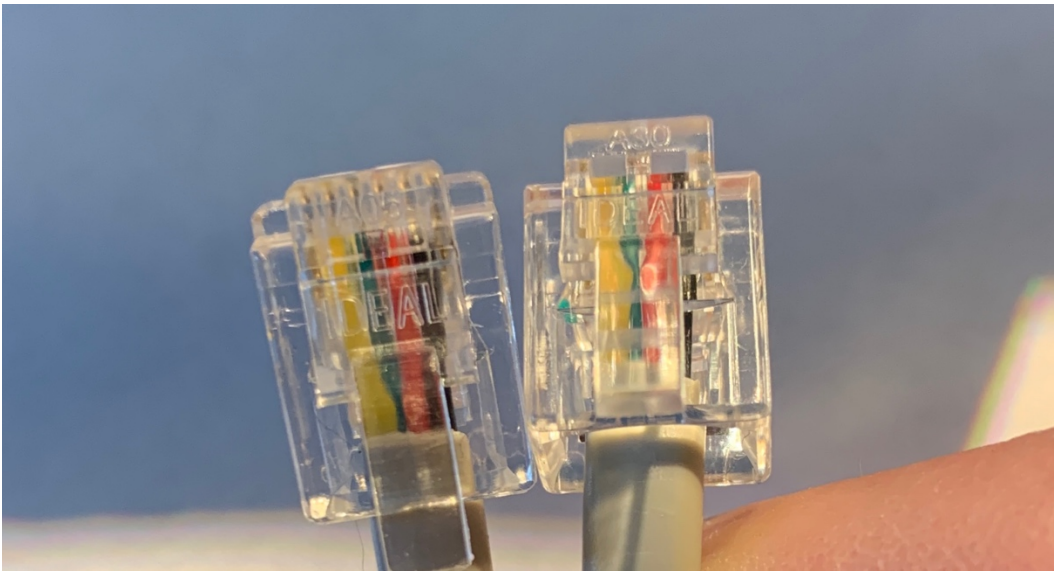

Make sure you plug the anemometer into the anemometer plug and the rain bucket into the rain bucket plug.



Raspberry Pi Power Wiring

Take the included USB Type A to Micro cable and connect it from the USB Plug panel connector to the power supply on the Raspberry Pi.



SkyWeather Wiring

The rest of the SkyWeather wiring instructions are identical to the instructions in the SkyWeather Assembly and Testing Manual. Please refer to that manual to finish the box wiring.

Testing

The process of testing the boxed SkyWeather system is identical to the process of testing the SkyWeather system in the SkyWeather Assembly and Testing Manual.

You have now completed your SkyWeather Kit.

The Science and Education Goals Behind SkyWeather

Everything we build for the Maker market is designed for education and learning. Making is education. Making is learning. Building your own projects allows you to innovate around a framework and do wonderful things that we have never thought of.

The educational goals for Smart Plant are:

- Learn about the Raspberry Pi and installing software on the Pi
- Connecting up sensors to the Raspberry Pi
- Learning about Feedback loops and regulating water to plants
- Understand your indoor environment and what affects it
- Learn about the new technology called the Internet of Things

SkyWeather designed to be the hub to which you connect everything to turn your Raspberry Pi into a complete Weather Station that talks to the Cloud. Just ready to be customized to your project and usage. It is designed to be a great way of learning to hook up hardware to the Raspberry Pi. And you have all the source code to modify to work the way you want it to do.

Our partnership with WeatherSTEM brings this kickstarter into the realm of cloud based data mining, great graphics displays and even time lapse photography. SkyWeather and WeatherSTEM together rock.

This is a great kit in which to learn about weather sensing, data sharing in the cloud and the Raspberry Pi.

Support

As with all SwitchDoc Labs products, technical support is given through the forums on Forum.switchdoc.com

If you have issues that can be solved by our fabulous customer service department, please go to www.switchdoc.com and send your issues through our Contact page on the top menu.

Disclaimer

SwitchDoc Labs, LLC takes no responsibility for any physical injuries and possession loss caused by those reasons which are not related to product quality, such as operating without following the operating manual and cautions, natural disasters or force majeure.

SwitchDoc Labs, LLC has compiled and published this manual which covers the latest product description and specification. The contents of this manual are subject to change without notice.