

SwitchDoc Labs



SkyWeather WXLINK Assembly and Testing Guide

May 2019
Version 1.2

Table of Contents

Errata	2
What is SkyWeather?	3
SkyWeather Features	3
Versions of SkyWeather	5
SkyWeather	5
SkyWeather Lite.....	5
SkyWeather Solar.....	5
SkyWeather Plus Solar WXLink Remote	5
Preparing and Learning your Raspberry Pi.....	5
What is in the SkyWeather Box.....	9
Step by Step Assembly.....	15
Setting up the Raspberry Pi	Error! Bookmark not defined.
I2C Sensor Connections	Error! Bookmark not defined.
What is I2C?	Error! Bookmark not defined.
Step By Step	Error! Bookmark not defined.
GPIO Connections	Error! Bookmark not defined.
What is GPIO?	Error! Bookmark not defined.
Step By Step	Error! Bookmark not defined.
WeatherRack Weather Instruments Assembly	Error! Bookmark not defined.
Final Assembly Pictures	Error! Bookmark not defined.
Wiring Lists for SkyWeather.....	Error! Bookmark not defined.
SkyWeather Initial Testing	17
Power Up your Raspberry Pi	Error! Bookmark not defined.
Test 1 – Verify I2C Devices.....	Error! Bookmark not defined.
Test 1A – Verify Detectable I2C devices	Error! Bookmark not defined.
Test 1-B - Testing the AM2315.....	Error! Bookmark not defined.
Test 1C - Test AS3935 ThunderBoard Lightning Detector	Error! Bookmark not defined.
Test 2 – Testing Specific GPIO Connected Devices (and the WeatherRack) ..	Error! Bookmark not defined.
Test 2A – Testing the Dust Sensor	Error! Bookmark not defined.
Test 2B – The TSL2591 Sunlight Sensor Test	Error! Bookmark not defined.
Test 3 – Testing SkyWeather Device Detection	Error! Bookmark not defined.
The Science and Education Goals Behind SkyWeather.....	26
Support.....	27
Disclaimer	29

Errata

Version 1.2 – Clarified contents of SkyWeather WXLink Kit

What is SkyWeather?

This is a perfect project kit for kids with some help from the adults and for adults trying to learn some new things. We have done this before with our successful OurWeather KickStarter so we know what we are talking about. People all over the world have built the OurWeather weather station with great success. This project has **no soldering** involved and uses Grove connectors to wire everything up! You can't reverse them and blow things up. [Here is our tutorial on the Grove system.](#)

SkyWeather Features

- Barometric Pressure
- LIGHTNING!
- Outside Temperature
- Outside Humidity
- Altitude
- Inside Temperature (in box)
- Inside Humidity (in box)
- Air Quality - AQI (your own local Air Quality Sensor)
- Sunlight
- Wind Speed
- Wind Direction
- Rain
- All your weather information on the Cloud including history

Easy to build. Easy to learn about the IOT (Internet Of Things) and the Raspberry Pi.

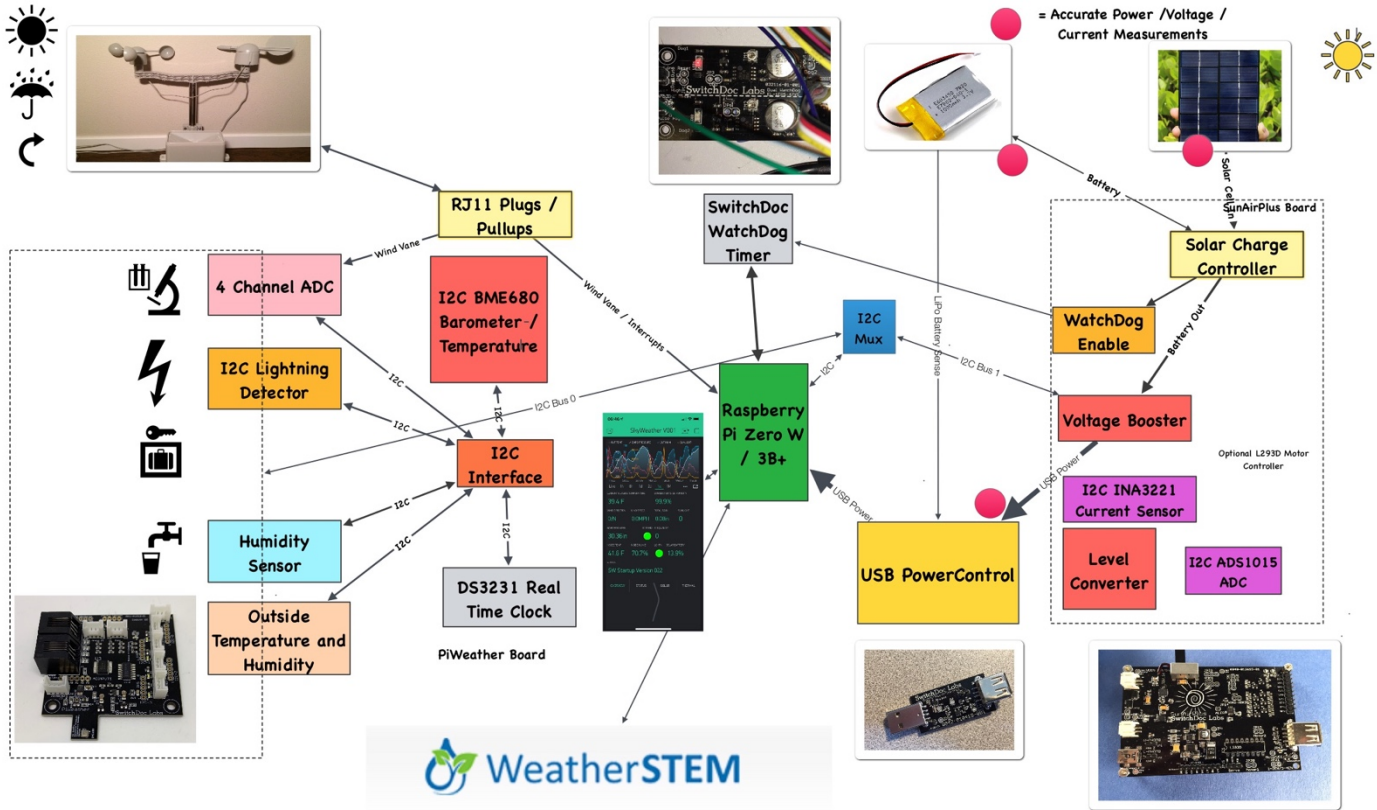

Versions of SkyWeather

SkyWeather

The full SkyWeather kit including the Lightning and Wind Direction, Speed and Rain sensors. Includes: Rain, Wind Speed / Direction, Lighting Detection, Outside Temperature and Humidity, Barometric Pressure, Internal Temperature/Humidity, Sunlight Strength, and Outside Air Quality.

SkyWeather Lite

SkyWeather Lite does not contain the Lightning Detector and the WeatherRack wind and rain sensors. Because of that, do not drill the holes for the Lightning Detector Pylon and you do not need to have the RJ11 box connectors for the WeatherRack

SkyWeather Solar

SkyWeather Solar adds a set of solar panels on the top of the SkyWeather Box. We have a special assembly manual for that add on to the SkyWeather kit. Note that you have to think about where and how to orient your solar panels versus the orientation you want for your Sky Camera. Solar Panels should generally point south (in the northern hemisphere) and north (in the southern hemisphere – right Topher?).

SkyWeather Plus Solar WXLink Remote

This SkyWeather package places the WeatherRack wind / rain sensors and the outside temperature and humidity sensor, along with a solar system in an external box connected by wireless LoRa. See the weatherproofing manual for the WXLink Box. Basically, you place the WeatherRack and the outside temperature / humidity sensors outside and the rest of SkyWeather can either be inside or outside. There are no wires between the WXLink remote box and the SkyWeather system. You may still want to place the Sky Camera and SkyWeather system outside and in that case you do not need to have the RJ11 box connectors for the WeatherRack or the hole AM2315 Outside Temperature and Humidity Sensor.

This manual is for the base SkyWeather kit.

Preparing and Learning your Raspberry Pi

The SkyWeather system requires a working Raspberry Pi. You can use virtually any not too old Raspberry Pi (2, 3, Zero, etc.) but you do need to set it up before starting the process of building SkyWeather.

Initial setting up your Raspberry Pi and connecting to it on your network is well beyond the scope of this manual. There are just too many variables in how you might set up your Raspberry Pi.

SwitchDoc Labs provides an SD Card that has the Raspberry Pi operating system, version Stretch, and all the SkyWeather software installed. <https://shop.switchdoc.com/products/16gb-sd-card-with-stretch-smart-garden-system-groveweatherpi>

Insert your SD Card (Part N from below if you have a SkyWeather Kit) into the Raspberry Pi SD Card. It goes colored face down on the Raspberry Pi 3B+ and face up on the Raspberry Pi ZeroW. The picture below shows the SD Card pluggend into a Raspberry Pi 3B+ (with the Pi2Grover board installed – Part A if you have the SkyWeather Kit).

(Default user: pi Default password: raspberry)

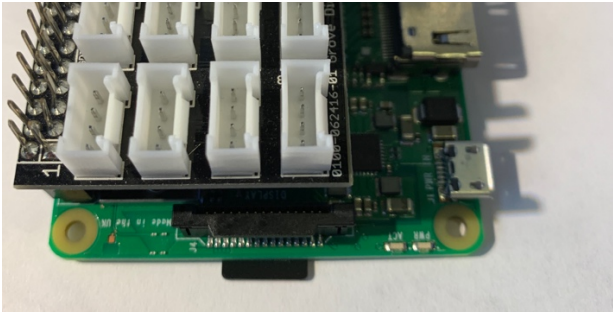

Once you have your Raspberry Pi setup up, running and can access a command line window (terminal) than you are ready to go with this manual.

This is the reason that we consider The SkyWeather Kit an advanced beginners kit, rather than a beginners kit (like the OurWeather Weather Station).

Here are some resources to get you set up and running as quickly as possible.

Helpful Getting Started Videos:

<https://www.raspberrypi.org/help/videos/>

Helpful Getting Started Written Tutorial:

<https://www.raspberrypi.org/wp-content/uploads/2012/12/quick-start-guide-v1.1.pdf>

If you want to set up a headless (no monitor, keyboard, mouse) Raspberry Pi, it is more complicated. Here are some links to tutorials for that process.

<http://www.circuitbasics.com/raspberry-pi-basics-setup-without-monitor-keyboard-headless-mode/>

<http://blog.self.li/post/63281257339/raspberry-pi-part-1-basic-setup-without-cables>

Many, many more tutorials are available on the web.

Once you have it set up, take a brief tutorial about using the terminal window and the very powerful Raspberry Pi Command Line.

<https://www.raspberrypi.org/blog/learning-the-command-line/>

<https://www.raspberrypi.org/blog/learn-to-love-the-command-line-with-the-magpi/>

You don't need to know a lot about the command line to enjoy building and running SkyWeather but you do need a bit of knowledge.

SkyWeather Solar WXLINK LoRa Kit

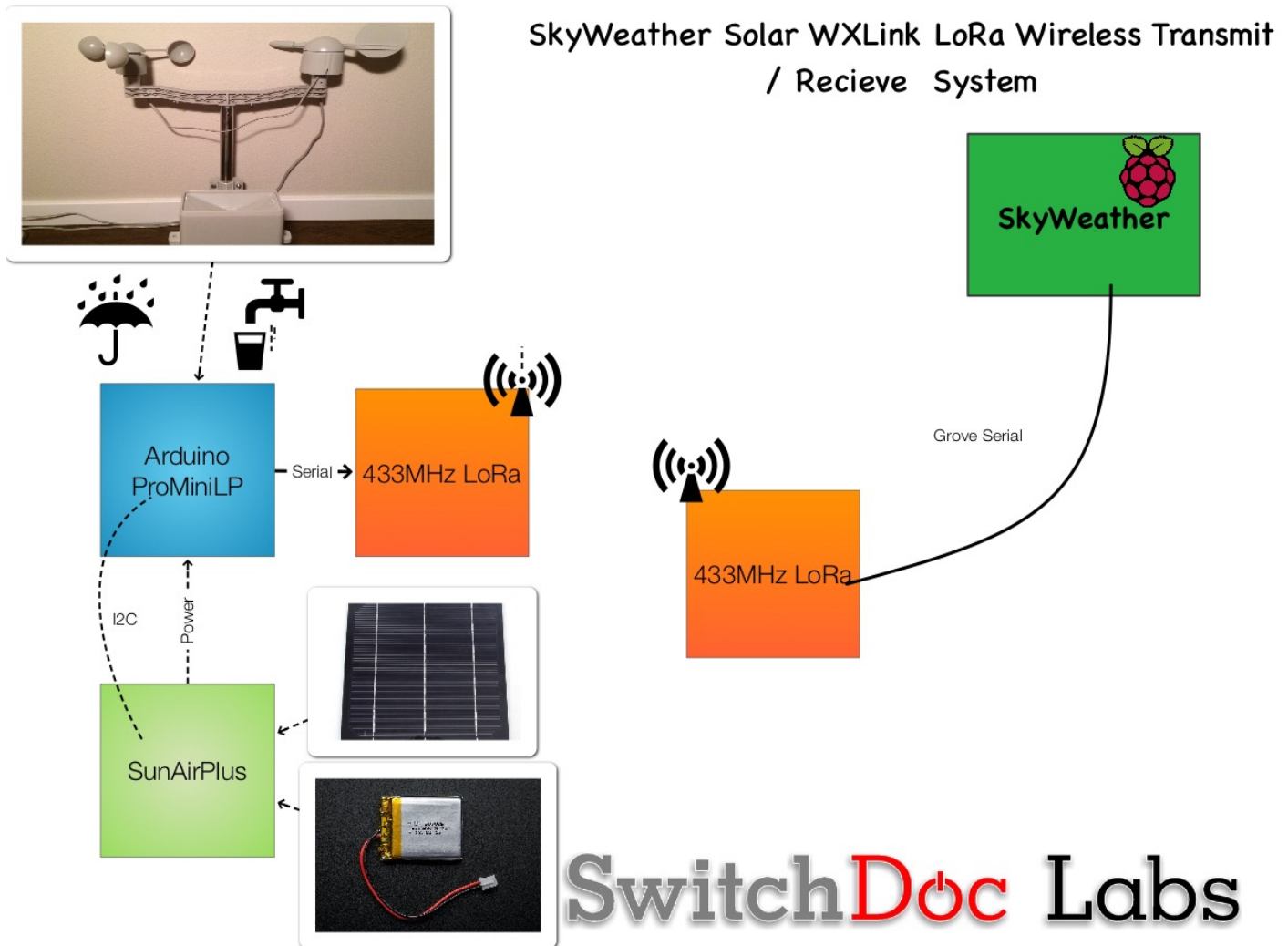

The issue is sometimes you don't want to run a wire all the way from the Weather Station to the wind and rain sensor. Using the Mini Pro LP, we built a WeatherRack reader and then we use a transmitter to send it back to the SkyWeather station inside. We then added solar power to the system.

The Solar WXLINK LoRa SkyWeather product kit contains one Mini Pro LP Arduino board, a WXLINKWR Weather Rack Interface board, two LoRa transceivers, SunAirPlus Solar Power Controller and Data Collector, and a 330mA 6V Solar Cell..

The SkyWeather Solar WXLINK Kit is a solar powered wireless serial link that can transmit up to 6000 meters in free air, with the proper antenna (like our Yagi Antenna product). It is designed to connect up to any source of data from sensors connected to the Mini Pro LP Arduino compatible low power computer board. It was specifically designed to connect a WeatherRack weather sensor array to a SKYWeather based system connected to a Raspberry Pi computer. And yes, it has Grove connectors throughout the system. The WXLINK LoRa comes preloaded with the software to support a WeatherRack and AM2315. See below for the source code. **No soldering required.**

This design uses SunAirPlus which collects (and transmits the information back to the weather station) information on the power system (Solar Panel Voltage/Current, Load Voltage/Current, Battery Voltage/Current). A GREAT science project! Lots of dataThe serial link is bi-Directional although the software currently just supports a uni-directional link.

This kit contains:

- One Mini Pro LP Arduino Boards
- One WXLinKWR Weather Rack Interface Board
- Two Grove 433MHz LoRa boards
- 5 20 CM Grove Cables
- SunAirPlus Solar Panel Controller / Data Collector (includes Pin Header to Grove Plug Cable)
- USB Type A Cable from SunAirPlus to micro USB Mini Pro LP Rx Arduino Board
- Two 330mA/6V Solar Panels with JST-2 Plug for SunAirPlus
- Multi Solar Panel Connector Board

Grove 433MHz LoRa Transceiver

The main functional module in the LoRa Radio 433MHz is RFM98, which is a transceiver features the LoRa long range modem that provides ultra-long range spread spectrum communication and high interference immunity whilst mini-missing current consumption. The CPU on board the LoRa Radio 433MHz is an ATmega168,

There is also an integrated a s wire antenna to receive and transmit the signal, if the signal is too weak to receive,, you can use the MHF connector next to the wire antenna.

This is the 433MHz version.

Note

- Keep the antenna vertical to the board and as straight as possible
- Avoid having any big metal object near the antenna

Features

- Uses RFM95 module based on SX1276 LoRa®
- ~28mA(Avg) @+20dBm continuous transmit
- ~8.4mA(Avg)@standby mode
- ~20mA(Avg) @receive mode, BW-500kHz
- Simple wire antenna or MHF Connector for external high gain antenna
- +20dBm - 100 mW Power Output Capability

You can set the UART baud rate, frequency, output power, data rate, frequency deviation, receiving bandwidth parameters, etc. It comes pre-programmed for 433MHz and 9600 baud.

The 433Mhz LoRa board is rated for 6000 meters in free air. Free air means with no obstruction and line of sight. Anything in your way reduces the received power and reduces the range. To test the range, We took the solar powered transmitter system on a walk down to the Spokane River. We ran two tests. One with the receiver behind three interior walls and one exterior wall and then repeated the test with the receiver only behind one interior wall. We specifically looked for continuous data flow. We found we could go about 5% or 10% further and still get a packet now and again.

Table 1 - Tested Transmission Distance

Receiver Condition	Maximum Transmitter Distance
Behind 3 Interior / 1 Exterior Wall	220 meters / 720 feet
Behind 1 Exterior Wall	438 meters / 1437 feet
Yagi Antenna on Transmitter	1600 meters / 5200 feet

What do I Do First?

The first thing to do is assemble and test the base SkyWeather Kit. Test everything! Remember, since you have a wireless link from the Weather Instruments to your SkyWeather base unit, you may choose not weatherproof your base SkyWeather kit. Just make sure you that your SkyCamera can see the sky outside!

What is in the SkyWeather WXLink Box

A Raspberry Pi is NOT included and must be purchased separately. Any Raspberry Pi with a 40 pin GPIO connector will work (such as the Raspberry Pi 2, 3 or Zero). You will need to also purchase a 3.7V LiPo battery. Because this system is so low power, any size of LiPo battery greater than 1000mAh should work fine. The higher the mAh rating of the battery, the longer the streak of cloudy days your unit can run without solar power. Adafruit has a great selection of LiPo batteries. Make sure you buy one with a JST-2 plug.

Suggested LiPo batteries:

2000mAh <https://www.adafruit.com/product/2011>

4400mAh <https://www.adafruit.com/product/354>

6600mAh <https://www.adafruit.com/product/353>

Any of these batteries will work and it is likely you can use the 2000mAh battery for this project as it is so low power.

Part AA – Two (2) Grove LoRa Transceivers

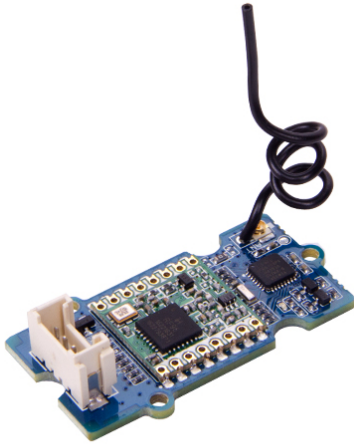

Part AB – Mini Pro LP Arduino

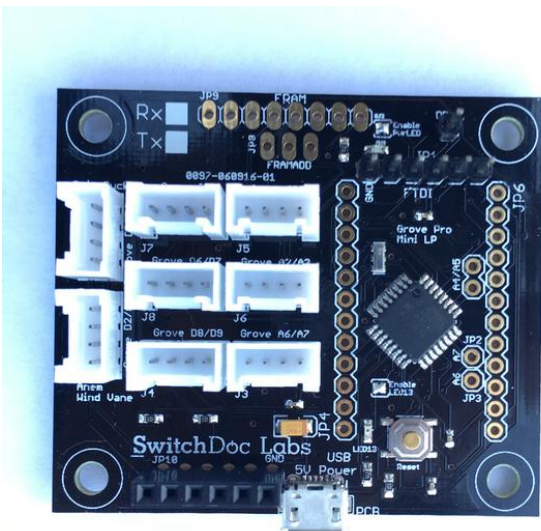

Part AC – WXLinkWR – WeatherRack Interface Board

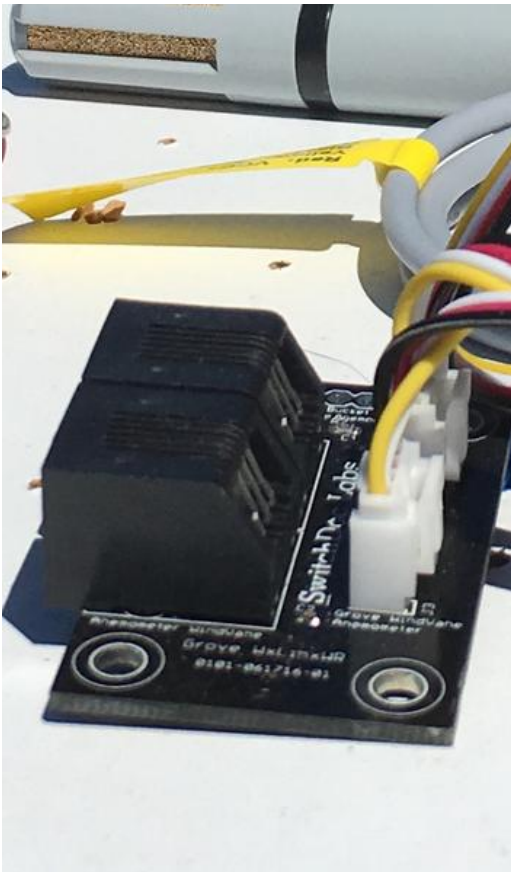

Part AD – SunAirPlus Solar Power Controller (With PinHeader to Grove Adaptor)



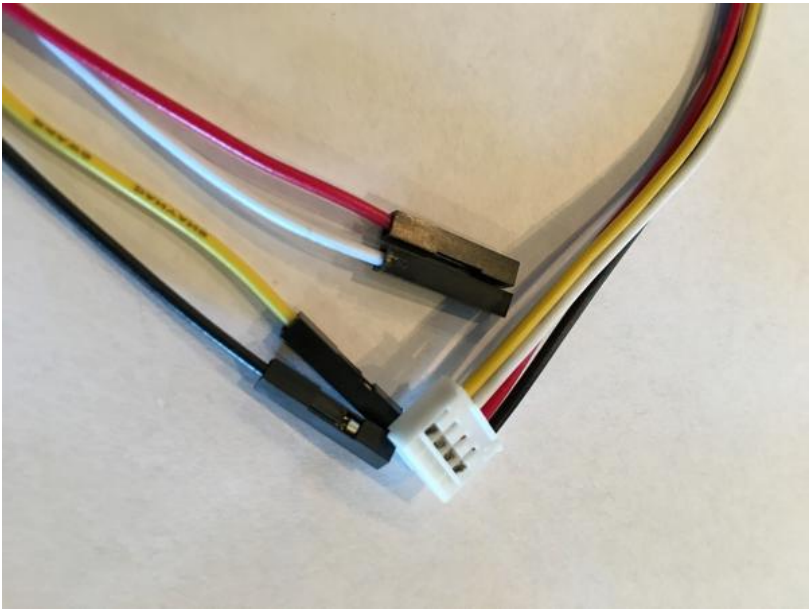
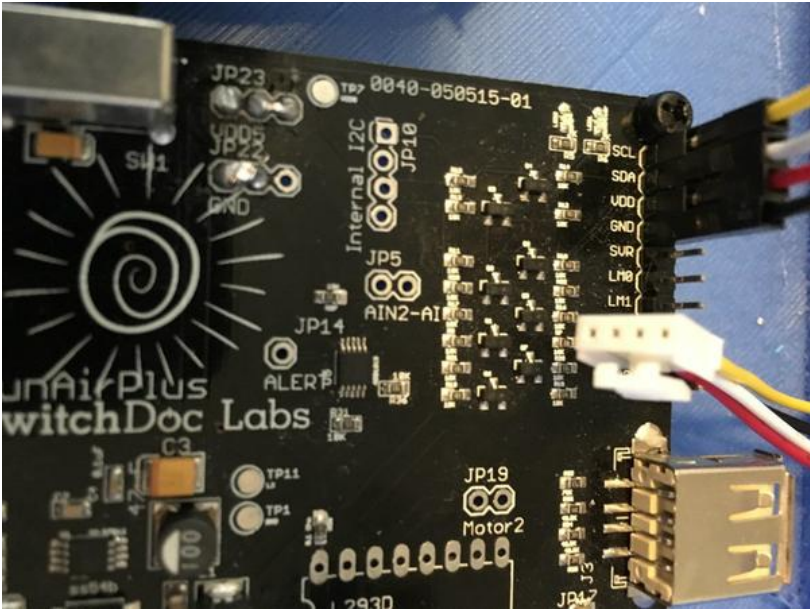

Part AE – Two (2) 330mA Solar Panels



Part AF – Five (5) 20cm Grove Cables



Part AG – USB Cable – Type A USB to Micro USB



Part AH – Solar Panel Multi Connect Board

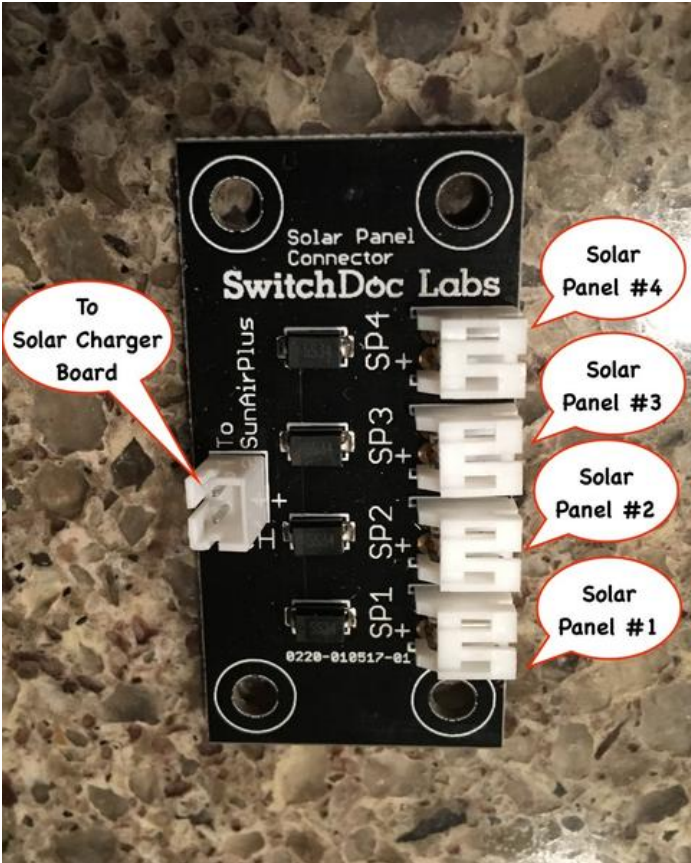

Step by Step Assembly

Make sure you have assembled and tested your SkyWeather Kit before proceeding.

SkyWeather Base Assembly Changes

Step 1) Remove the WeatherRack RJ11 plugs from your SkyWeather Kit. You connect the WeatherRack to your WXLlink kit.

Step 2) Remove the AM2315 Temperature Humidity Sensor from your SkyWeather Kit. You use this sensor in the WXLlink kit.

Step 3) Using a 20cm Grove Cable (Part AF) plug one end into one of the Grove LoRa Transceiver board (Part AA)

Step 4) Connect the other end of the 20cm Grove Cable (Part AF) from Step 3) into the Grove Serial Port on your Pi2Grover Board in SkyWeather.

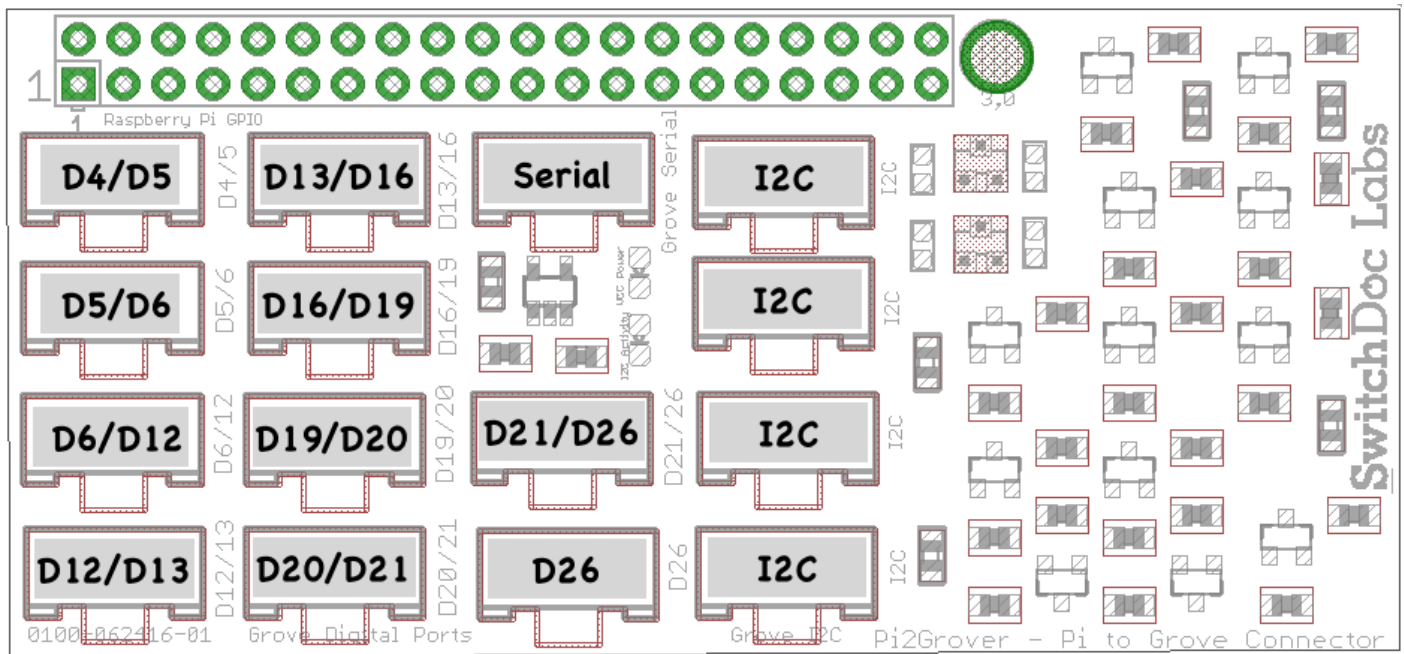

This completes the SkyWeather base unit part of the assembly. When you start up SkyWeather next, the software will automatically pick up the Grove LoRa and switch to WXLlink mode.

Solar WXLlink Assembly

Step 5) Take the Grove Pin Header to Grove Connector Cable from SunAirPlus (Part AD) and connect the pin headers to the Pins on the top right of the SunAirPlus board as seen in the picture. Make sure you connect the colors properly and in the order shown.

Yellow – SCL
White – SDA
Red – VDD

Black – GND

Double check your wiring!

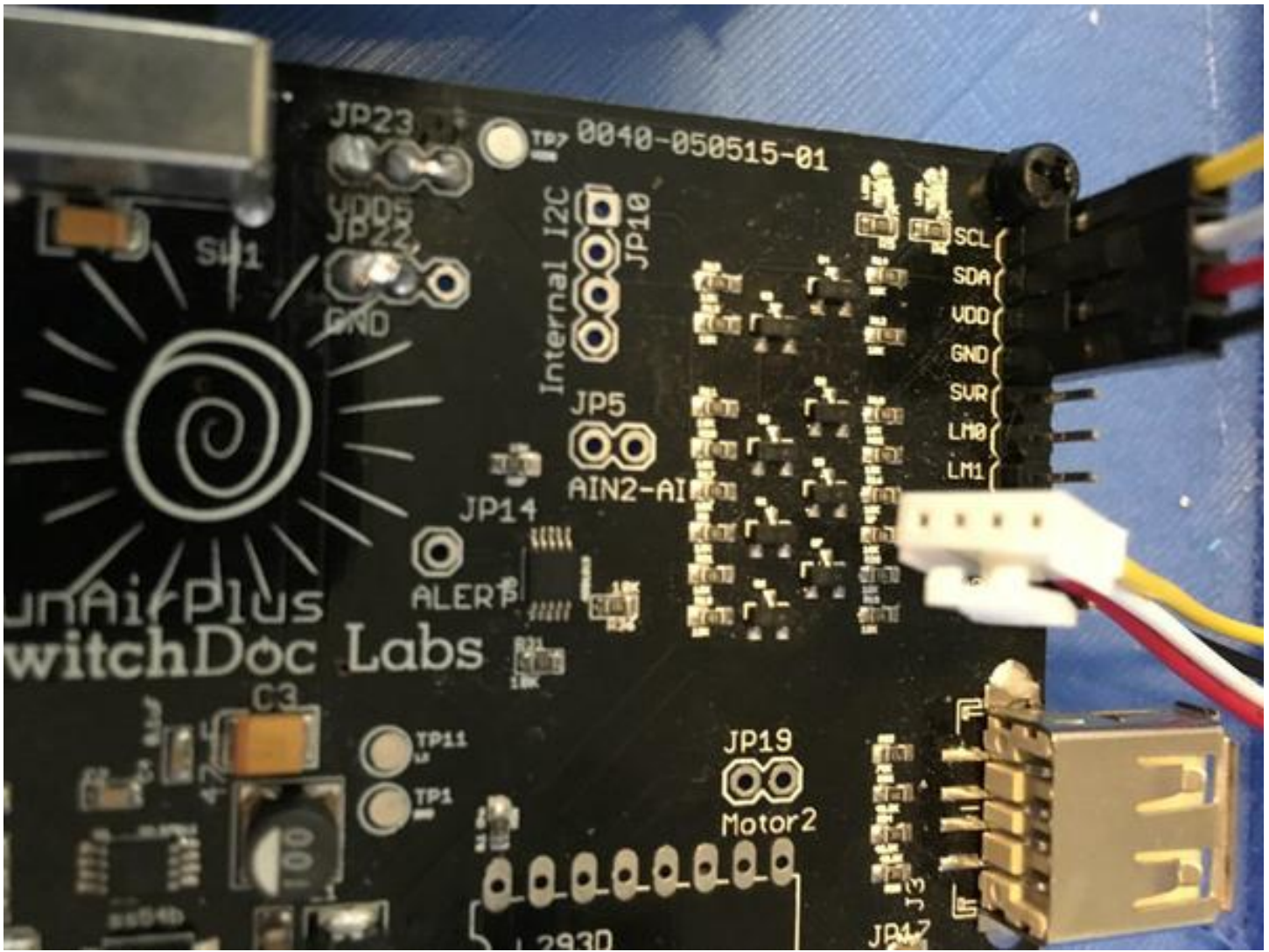

Step 6) Plug the Grove Cable from SunAirPlus (Part AD) to one of the I2C Ports on the Mini Pro LP Board (Part AB).

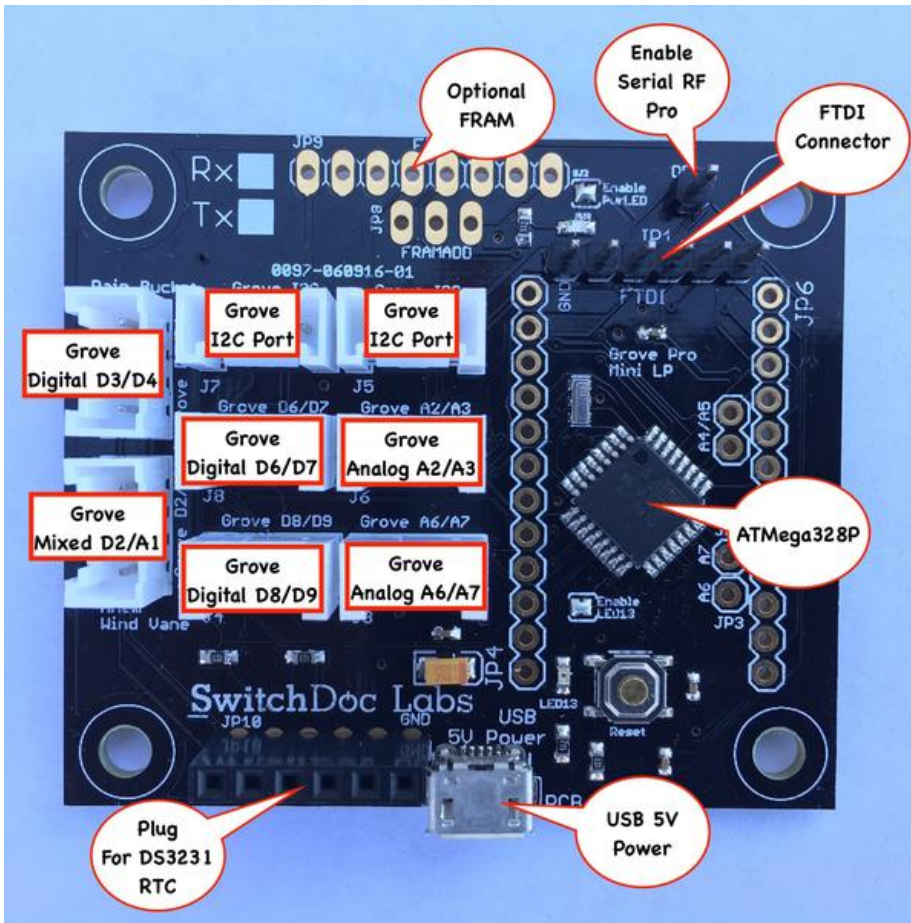

Step 7) Plug the Grove Cable from the AM2315 Temperature / Humidity Sensor (that you disconnected from SkyWeather in Step 2) into the other I2C Port on the Mini Pro LP Board (Part AB).

Step 8) Plug the second Grove LoRa Transceiver (Part AA) into the port D6/D7 on the Mini Pro LP Board (Part AB).

Step 9) Plug a Grove Cable (Part AD) into WXLInkWR (Part AC) Port Grove Rain Bucket.

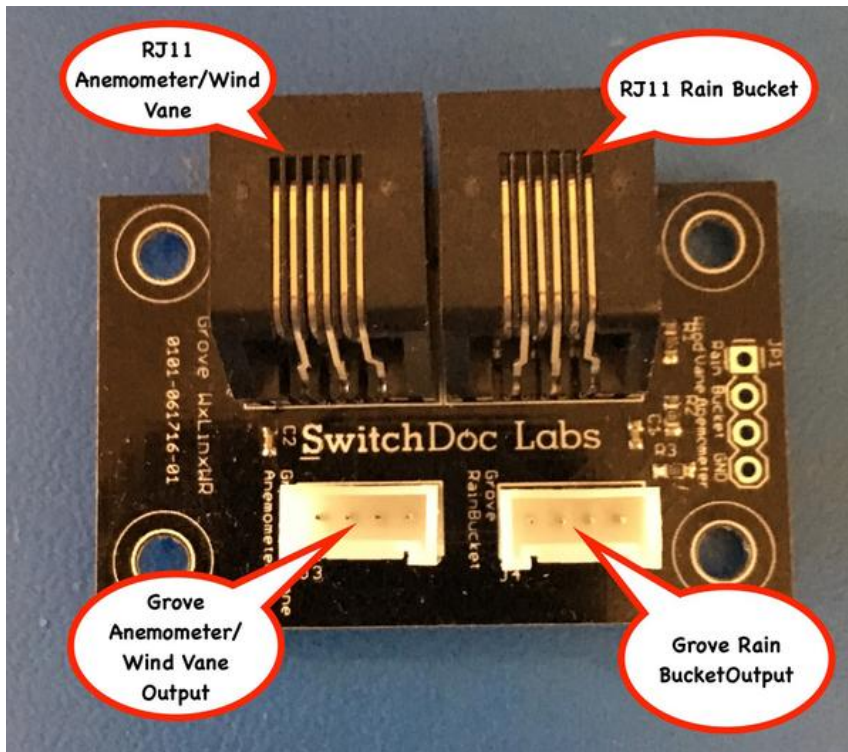

Step 10) Plug the other end of the Grove Cable (Part AD) from Step 9 into the port D3/D4 on the Mini Pro LP Board (Part AB).

Step 11) Plug a Grove Cable (Part AD) into the WXLinWR (Part AC) Port Grove Anemometer / Wind Vane Output.

Step 12) Plug the other end of the Grove Cable (Part AD) from Step 11 into the port D2/A1 on the Mini Pro LP Board (Part AB).

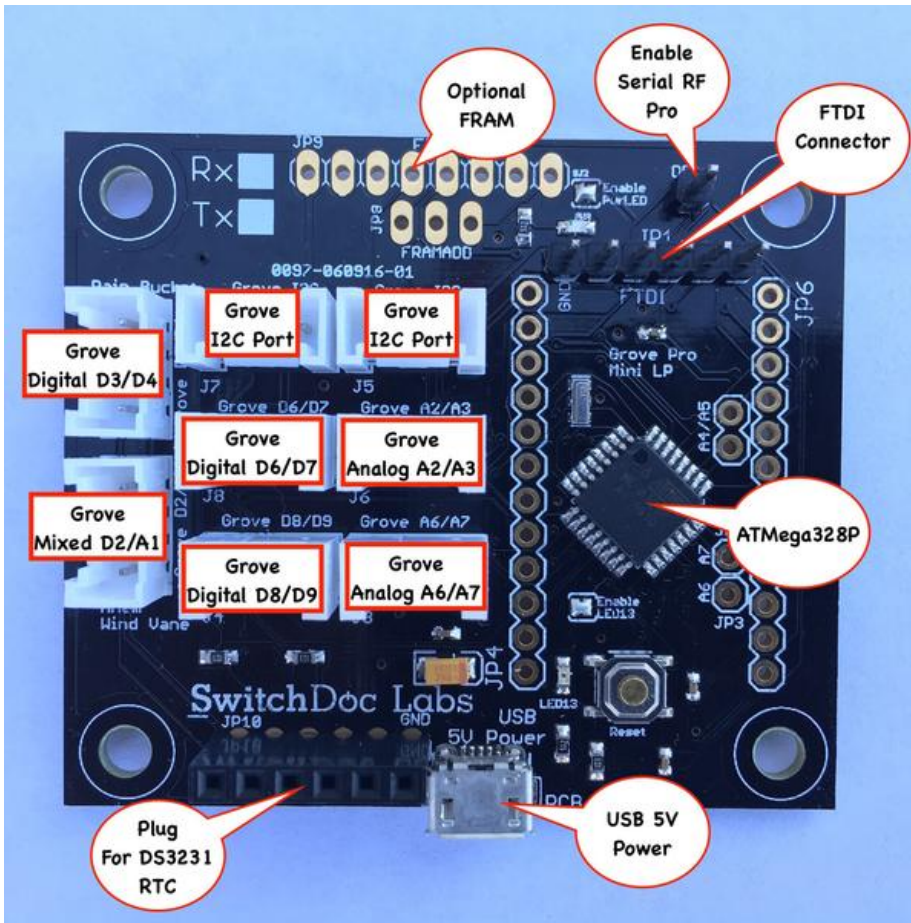

Step 13) Plug the JST2 Plug on one of the 330mA Solar Panels (Part AE) into the Solar Panel #1 Plug on the Multiple Solar Panel Connector Board (Part AH).

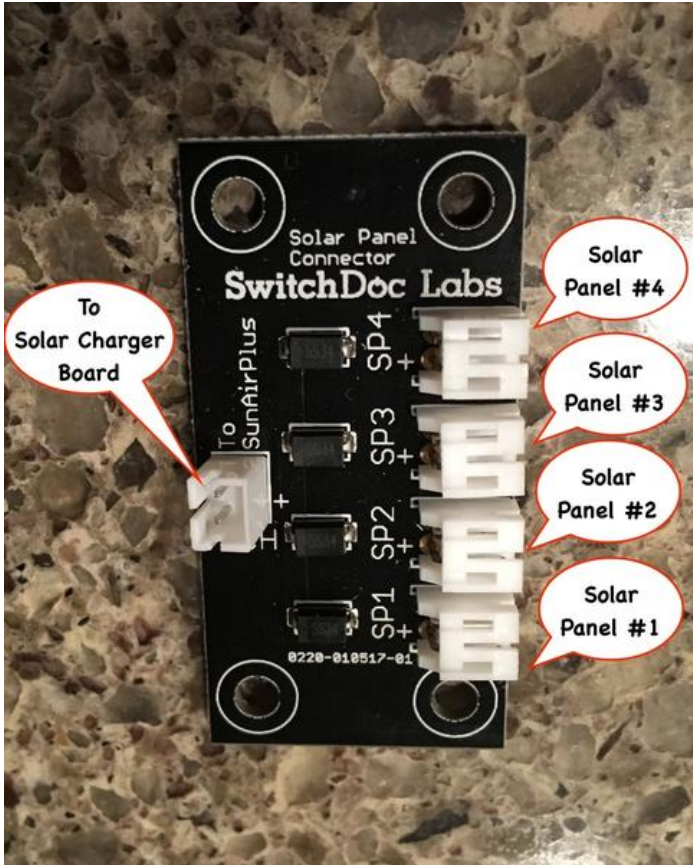

Step 14) Plug the JST2 Plug on the other 330mA Solar Panels (Part AE) into the Solar Panel #2 Plug on the Multiple Solar Panel Connector Board (Part AH).

Step 15) Plug the JST2 Extender Cable that comes with the Multiple Solar Panel Connector Board (Part AH) from the “To Solar Charger” board port to the Solar JST2 plug on SunAirPlus (Part AD).

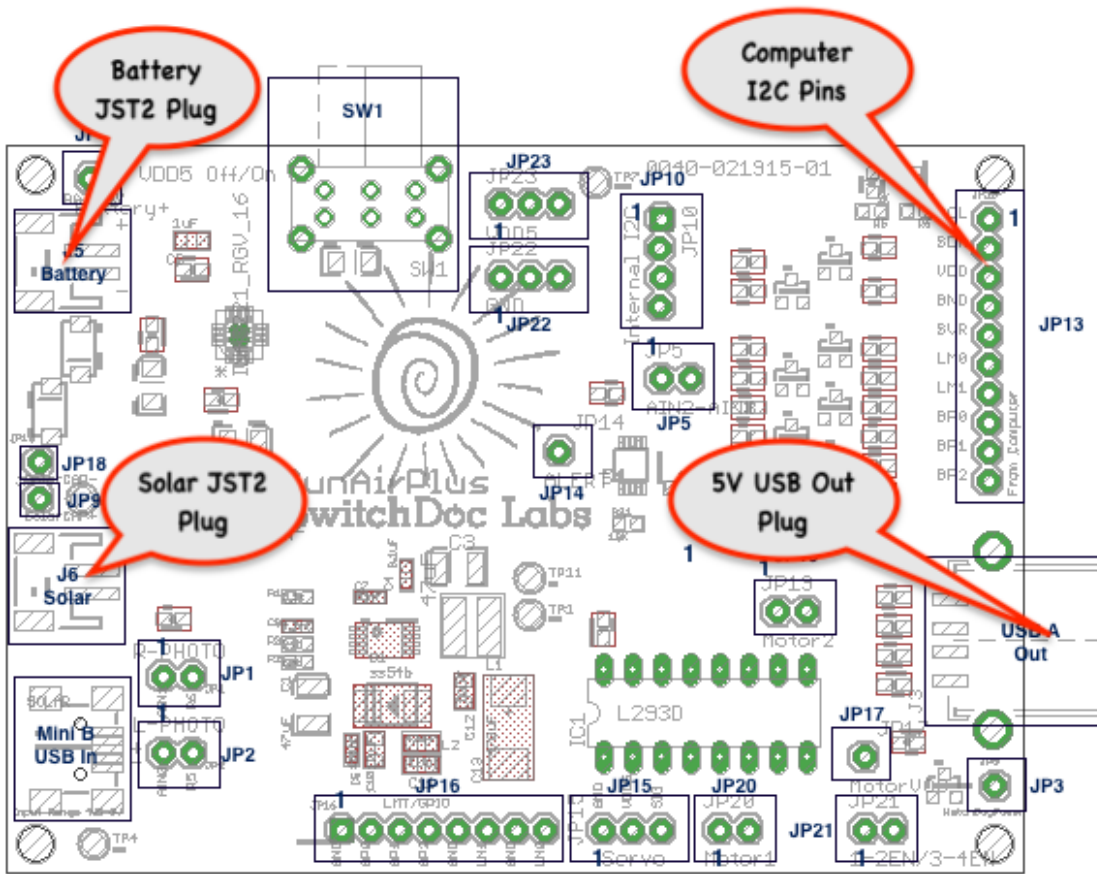

Step 16) Plug the USB Type A to Micro USB Cable (Part AG) from the 5V USB Out Plug on SunAirPlus (Part AD) to the MicroUSB Plug on the Mini Pro LP (Part AB).

Step 17) Plug the RJ11 cable from the Rain Bucket on your WeatherRack (from the SkyWeather Kit) into the RJ11 Rain Bucket Plug on the WXLINKWR Board (Part AC).

Step 18) Plug the RJ11 cable from the Wind Vane on your WeatherRack (from the SkyWeather Kit) into the RJ11 Anemometer / Wind Vane plug on the WXLINKWR Board (Part AC).

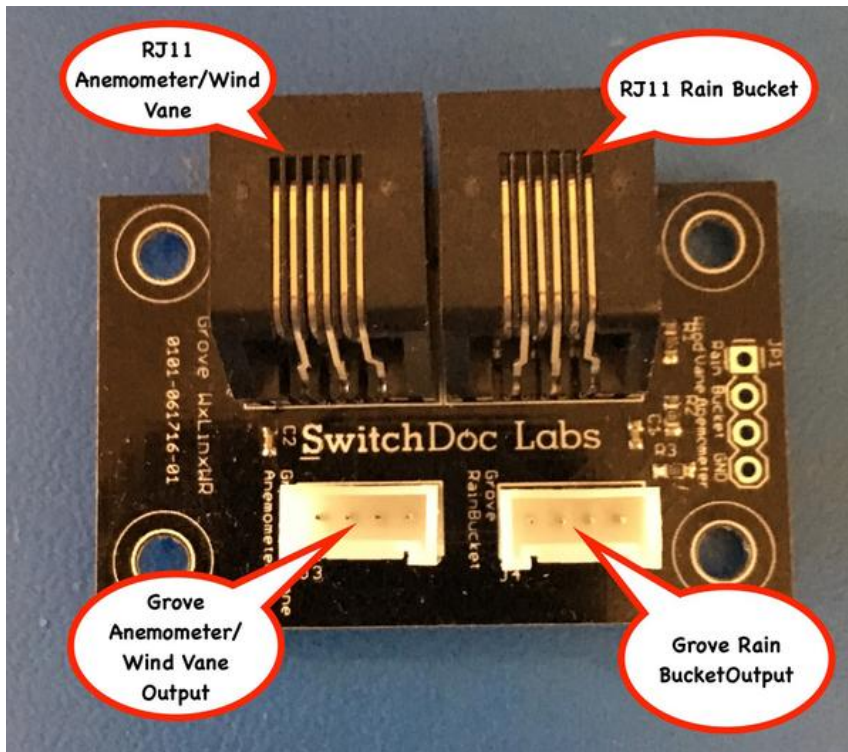

Step 19) Turn the switch on top of the SunAirPlus (Part AD) board to the Left to turn OFF the board.

Step 20) Plug your 3.7V LiPo battery (not included) into the Battery JST2 Plug on SunAirPlus (Part AD).

Step 21) Turn the switch on top of the SunAirPlus Board (Part AD) to the right to turn ON the system. Unless your battery is discharged, you should see LEDs come on on the SunAirPlus board (Part AD) and the Mini Pro LP Board (Part AB). If you expose the Solar Panels (Parts AE) to a bright light, you should see a red LED on the SunAirPlus (Part AD) that indicates the board is charging.

When you turn it on, WXLink will start broadcasting about every 30 seconds Now we need to do some testing.

SkyWeather Solar WXLink Initial Testing

SkyWeather Solar WXLink operations again are similar to the full kit. The Solar WXLink allows you to mount the AM2315 and the WeatherRack sensors in a remote location from your Raspberry Pi. While the Solar WXLink only contains solar panels and a SunAirPlus controller for the WeatherRack and AM2315. This means that these devices are not read from the local unit and will instead be read from the WXLink. If SkyWeather detects the WXLink then it will read the data from there. Note that the startup of reading the WXLink can take some time (even minutes) before it will start reading. A quick way of testing the WXLink (obviously after you have assembled it) is to run the testWXLink.py program located in the SDL_Pi_SkyWeather main directory.

```
cd SDL_Pi_SkyWeather
sudo python testWXLink.py
```

```
'HW-Version: ', 18)
```



```

after WXLink waitRX
-----
block1= [171, 102, 37, 71, 81, 52, 0, 0, 0, 215, 151, 202, 64, 153, 0, 0, 0, 0, 0, 0, 0, 0, 0, 0, 0, 0, 0, 0, 0, 205, 204, 132, 65, 0, 0, 40]
block2= [66, 129, 149, 131, 64, 51, 51, 51, 66, 204, 204, 60, 66, 162, 69, 150, 64, 204, 204, 204, 65, 0, 0, 0, 0, 96, 26, 0, 0, 236, 197]
-----
block 1
ab662547513400000d797ca4099000000000000000000000cdcc8441000028
block 2
428195834033333342cccc3c42a2459640cccccc4100000000601a0000ecc5
-----
ReversedreceivedCRC= ecc5
length of stb1+sb2= 59
ab662547513400000d797ca4099000000000000000000000cdcc8441000028
428195834033333342cccc3c42a2459640cccccc4100000000601a
calculatedCRC = ecc5
Good CRC Received
Rain Total= 0.00 in
Wind Speed= 3.96 MPH
Wind Direction= 0 Degrees
OTFloat=cdcc8441
AM2315 from WXLink temperature: 16.6C
AM2315 from WXLink humidity: 42.0%
WXLink batteryVoltage = 4.11
WXLink batteryCurrent = 44.80
WXLink loadCurrent = 47.20
WXLink solarPanelVoltage = 4.70
WXLink solarPanelCurrent = 25.60
WXLink auxA = 0.00
WXLink Message ID 6752
WXLink_Data_Fresh set to True
ReversedreceivedCRC= ecc5
length of stb1+sb2= 59

```

Note that the WXLink device will take some time to sync in (especially if you are in an electrically noisy environment) and you may see a number of bad CRCs from that kind of environment. If you don't see good messages after a while, move the LoRa receiver plugged into your Raspberry Pi to a place farther away from sources of noise (like phones, monitors and 3D printers – our 3D printer is munching our LoRa receiver right now!). These kind of errors look like:

```

ReversedreceivedCRC= 128b
length of stb1+sb2= 59
ab6625eb4e3400000301534404400000000000000000000066668641333327
4281958340ffff074200002042a24596409999c941000000005f1a
calculatedCRC = 12cb
Bad CRC Received

```

If you are not using a solar powered system on your base unit (which you can use – it is just not one of the pre-packaged kits), then the SkyWeather software will put the WXLink solar system information into the data structures reserved for the base unit solar power data. That way you can monitor your remote WXLink power.

If you have a solar system on your base unit, then SkyWeather will use the base unit solar information for the displays and the MySQL database. If you want both, some modifications to the software are needed, which is beyond the scope of this manual.

SkyWeather Initial Testing

Now to run the system test.

Open a command line terminal window.

```
cd SDL_Pi_SkyWeather
sudo pigpiod
sudo python SkyWeather.py
```

Make sure you have the Grove LoRa Transciever plugged into your Pi2Grove Board. The SkyWeather System will automatically configure itself.

You should see something like this:

```
pi@switchdoclabs:~/SDL_Pi_SkyWeather $ sudo python SkyWeather.py
(15.177600000000002, 7, 2)
()
('Pi Camera Revision', u'ov5647')
('HW-Version: ', 18)
('after bme680', True)
as3935 start
as3935 present at 0x02
```

SkyWeather Weather Station Version 034 - SwitchDoc Labs

Program Started at:2019-05-05 16:13:46

```
-----
I2C Mux - TCA9545:                Present
BME680:                            Present
BMP280:                            Not Present
SkyCam:                            Present
DS3231:                            Not Present
HDC1080:                            Not Present
AM2315:                            Not Present
ADS1015:                            Not Present
ADS1115:                            Present
AS3935:                            Present
OLED:                              Not Present
SunAirPlus:                        Not Present
SI1145 Sun Sensor:                 Not Present
TSL2591 Sun Sensor:                Present
DustSensor:                        Present
WXLink:                            Present

UseBlynk:                          Present
UseMySQL:                          Present
Check WLAN:                        Present
WeatherUnderground:                Not Present
UseWeatherStem:                   Present
-----
sendmail exception raised
-----
Sample and Display
-----
Weather Sampling
-----
Bad data from WXLink, discarded new data. Kept old
-----
SunAirPlus Not Present
-----
-----
AS3935 Lightning Detector
```

Last result from AS3935:
----No Lightning detected---
Lightning Count = 0

Sample and Display Done

Scheduled Jobs

Jobstore default:

patTheDog (trigger: interval[0:00:10], next run at: 2019-05-05 16:14:09 PDT)
checkForButtons (trigger: interval[0:00:10], next run at: 2019-05-05 16:14:09 PDT)
readRawWXLink (trigger: interval[0:00:15], next run at: 2019-05-05 16:14:14 PDT)
sampleAndDisplay (trigger: interval[0:00:30], next run at: 2019-05-05 16:14:29 PDT)
tick (trigger: interval[0:01:00], next run at: 2019-05-05 16:14:59 PDT)
takeSkyPicture (trigger: interval[0:01:00], next run at: 2019-05-05 16:14:59 PDT)
writeWeatherRecord (trigger: interval[0:05:00], next run at: 2019-05-05 16:18:59 PDT)
writePowerRecord (trigger: interval[0:05:00], next run at: 2019-05-05 16:18:59 PDT)
updateRain (trigger: interval[0:05:00], next run at: 2019-05-05 16:18:59 PDT)
checkForShutdown (trigger: interval[0:05:00], next run at: 2019-05-05 16:18:59 PDT)
doAllGraphs (trigger: interval[0:15:00], next run at: 2019-05-05 16:28:59 PDT)
barometricTrend (trigger: interval[0:15:00], next run at: 2019-05-05 16:28:59 PDT)
read_AQI (trigger: interval[0:15:00], next run at: 2019-05-05 16:28:59 PDT)
WLAN_check (trigger: interval[0:30:00], next run at: 2019-05-05 16:43:59 PDT)
statusRain (trigger: interval[1:00:00], next run at: 2019-05-05 17:13:59 PDT)
rebootPi (trigger: cron[day='5-30/5', hour='0', minute='4'], next run at: 2019-05-10 00:04:00
PDT)

-----Patting The Dog-----
-----Patting The Dog-----

-----Patting The Dog----- Sample and Display

Weather Sampling

Bad data from WXLink, discarded new data. Kept old

after WXLink waitRX

block1= [171, 102, 37, 192, 101, 88, 0, 0, 0, 114, 192, 227, 64, 172, 0, 0, 0, 13, 0, 0, 0, 0, 0,
0, 0, 0, 212, 65, 102, 102, 254]
block2= [65, 11, 215, 131, 64, 51, 51, 99, 66, 153, 153, 25, 66, 15, 45, 210, 64, 153, 153, 153,
64, 0, 0, 0, 0, 35, 48, 0, 0, 122, 64]

block 1
ab6625c065580000072c0e340ac000000d00000000000000000d4416666fe
block 2
410bd7834033336342999919420f2dd2409999994000000000233000007a40

SunAirPlus Not Present

AS3935 Lightning Detector

Last result from AS3935:
----No Lightning detected---
Lightning Count = 0

Sample and Display Done

```

-----Patting The Dog-----
-----Patting The Dog-----
Tick! The time is: 2019-05-05 16:14:59.057914
-----Patting The Dog-----
-----
Sample and Display
-----
Weather Sampling
-----
ReversedreceivedCRC= 7a40
length of stb1+sb2= 59
ab6625c0655800000072c0e340ac000000d00000000000000000d4416666fe
410bd7834033336342999919420f2dd240999999400000000002330
calculatedCRC = 7a40
Good CRC Recived
Rain Total= 0.51 in
Wind Speed= 4.45 MPH
Wind Direction= 0 Degrees
OTFloat=00d441
AM2315 from WXLink temperature: 26.5C
AM2315 from WXLink humidity: 31.8%
WXLink batteryVoltage = 4.12
WXLink batteryCurrent = 56.80
WXLink loadCurrent = 38.40
WXLink solarPanelVoltage = 6.57
WXLink solarPanelCurrent = 4.80
WXLink auxA = 0.00
WXLink Message ID 12323
WXLink_Data_Fresh set to True
-----
SunAirPlus Not Present
-----
AS3935 Lightning Detector
-----
Last result from AS3935:
----No Lightning detected---
Lightning Count = 0
-----
Sample and Display Done
-----

```

It may take a while to sync in, but you will eventually get data. If you don't, check your wiring very carefully. You can see what is going on with the WXLink by using an FTDI cable to check the serial port on the Mini Pro LP.

The Science and Education Goals Behind SkyWeather

Everything we build for the Maker market is designed for education and learning. Making is education. Making is learning. Building your own projects allows you to innovate around a framework and do wonderful things that of which we have never thought.

The educational goals for SkyWeather are:

- Learn about the Raspberry Pi and installing software on the Pi
- Connecting up sensors to the Raspberry Pi
- Learning about Feedback loops
- Understand your indoor environment and what affects it
- Learn about the new technology called the Internet of Things

SkyWeather designed to be the hub to which you connect everything to turn your Raspberry Pi into a complete Weather Station that talks to the Cloud. Just ready to be customized to your project and usage. It is designed to be a great way of learning to hook up hardware to the Raspberry Pi. And you have all the source code to modify to work the way you want it to do.

Our partnership with WeatherSTEM brings this kickstarter into the realm of cloud based data mining, great graphics displays and even time lapse photography. SkyWeather and WeatherSTEM together rock. This is a great kit in which to learn about weather sensing, data sharing in the cloud and the Raspberry Pi.

Wiring Lists and Wiring Diagram

WXLink Wiring LList		
From	To	Notes
TX Mini Pro LP Board / Grove Digital D2/A1	WXLinkWR / Grove J3 Anemometer/Wind Vane	Grove Cable
TX Mini Pro LP Board / Grove Digital D3/D4	WXLinkWR / Grove J4 Rain Bucket	Grove Cable
TX Mini Pro LP Board / Grove D6/D7	LoRa 433MHz Board for TX	Grove Cable - note: Both LoRa 433MHz boards are identical - pick one for TX and one for RX
TX Mini Pro LP Board / Micro USB Connector	SunAirPlus USB Connector	5V Power from SunAirPlus
TX Mini Pro LP Board / Grove I2C Plug (either plug)	SunAirPlus / "From Computer Header"	Wires on Grove Cable: Black - GND, Red - VDD, White - SDA, Yellow - SCL
LiPo Battery JST-2 Cable	SunAirPlus / Male JST-2 Labeled Battery	Battery to SunAirPlus
330mA/6V Solar Cell JST-2 Cable	SunAirPlus / Male JST-2 Labeled Solar	Solar Cell to SunAirPlus

SkyWeather Solar WXLink LoRa Tx

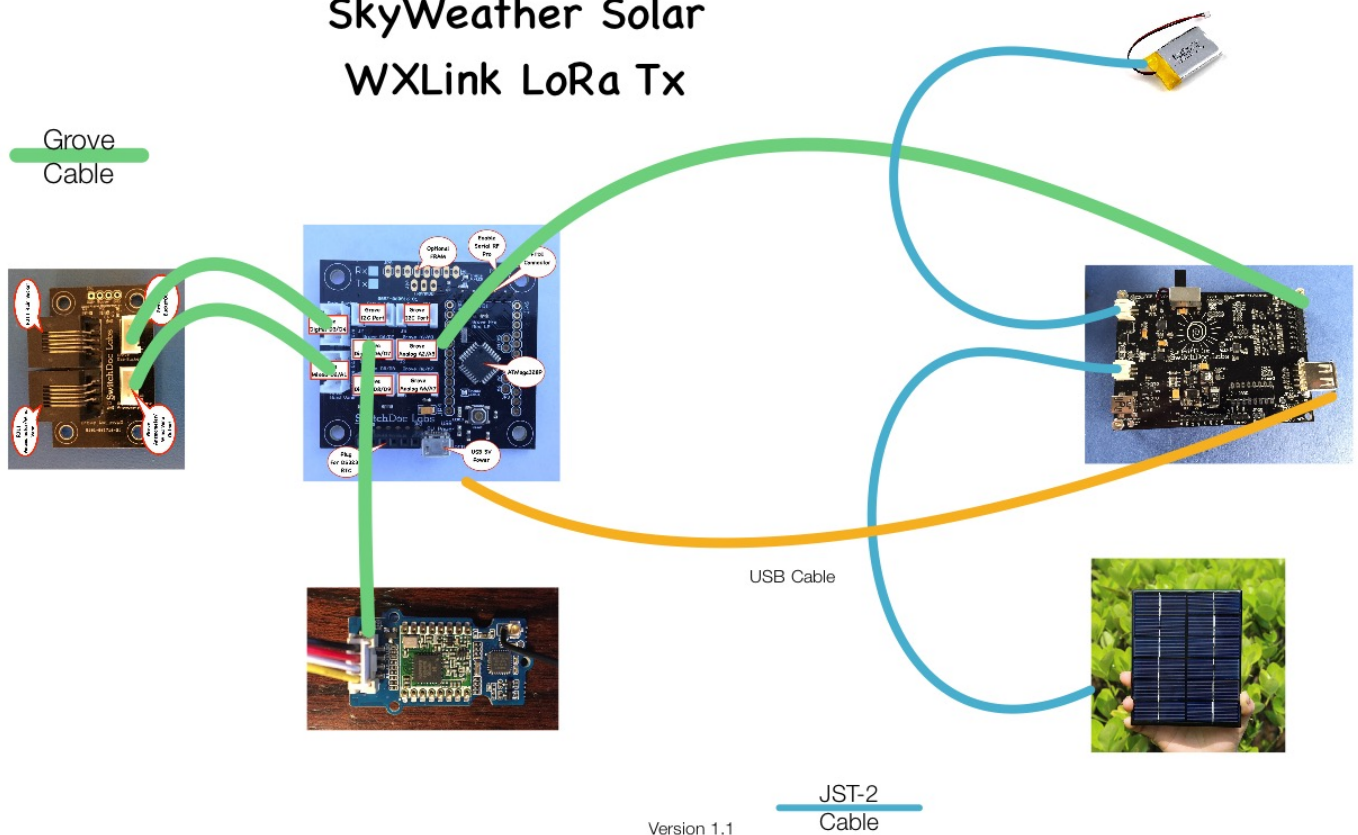

Support

As with all SwitchDoc Labs products, technical support is given through the forums on Forum.switchdoc.com. If you have issues that can be solved by our fabulous customer service department, please go to www.switchdoc.com and send your issues through our Contact page on the top menu.

Disclaimer

SwitchDoc Labs, LLC takes no responsibility for any physical injuries and possession loss caused by those reasons which are not related to product quality, such as operating without following the operating manual and cautions, natural disasters or force majeure.

SwitchDoc Labs, LLC has compiled and published this manual which covers the latest product description and specification. The contents of this manual are subject to change without notice.